



Bid Number/बोली क्रमांक (बिड संख्या):  
GEM/2022/B/2916958  
Dated/दिनांक : 14-01-2023

**Bid Document/ बिड दस्तावेज़**

<b>Bid Details/बिड विवरण</b>	
<b>Bid End Date/Time/बिड बंद होने की तारीख/समय</b>	13-02-2023 18:00:00
<b>Bid Opening Date/Time/बिड खुलने की तारीख/समय</b>	13-02-2023 18:30:00
<b>Bid Offer Validity (From End Date)/बिड पेशकश वैधता (बंद होने की तारीख से)</b>	120 (Days)
<b>Ministry/State Name/मंत्रालय/राज्य का नाम</b>	Ministry Of Finance
<b>Department Name/विभाग का नाम</b>	Department Of Economic Affairs
<b>Organisation Name/संगठन का नाम</b>	Security Printing And Minting Corporation Of India Limited (spmci)
<b>Office Name/कार्यालय का नाम</b>	Janpath
<b>Total Quantity/कुल मात्रा</b>	517
<b>Item Category/मद केटेगरी</b>	Thickness monitor for MRH MRV 150 , Guide piece for MRV 150 , Feed chute and Nylon insert for MRV 150 , Base Plate for feed chute for MRV 150 , Pusher for MRV 150 , Segment for MRV coining press , Coin plate A for MRH 150 , Coin plate B for MRH 150 , Swing plate assembly for MRH 150 , Coin Discharge Conveyor , Toggle Clamps 225U , Toggle Clamps 210U , Toggle Clamps 207U , Toggle Clamps 201U , Sprocket for Coin blank conveyor , Collar Switch assy for MRH 150 , Collar Switch assy for MRV 150 , FOUNDATION SPRING SCHULER PRESS , Reconditioning of indexing unit
<b>BOQ Title/बीओक्यू शीर्षक</b>	PROCUREMENT OF DENOMINATION CHANGE PARTS FOR NEW SERIES COINS AND SPARES FOR SCHULER COINING PRESS
<b>Minimum Average Annual Turnover of the bidder (For 3 Years)/बिडर का न्यूनतम औसत वार्षिक टर्नओवर (3 वर्षों का)</b>	22 Lakh (s)
<b>Years of Past Experience Required for same/similar service/उन्हीं/समान सेवाओं के लिए अपेक्षित विगत अनुभव के वर्ष</b>	1 Year (s)
<b>MSE Exemption for Years Of Experience/अनुभव के वर्षों से एमएसई छूट/ and Turnover</b>	Yes
<b>Startup Exemption for Years Of Experience/अनुभव के वर्षों से स्टार्टअप छूट/ and Turnover</b>	Yes

**Bid Details/बिड विवरण**

<b>Document required from seller/विक्रेता से मांगे गए दस्तावेज़</b>	Experience Criteria,Past Performance,Bidder Turnover,Certificate (Requested in ATC),OEM Authorization Certificate,Compliance of BoQ specification and supporting document *In case any bidder is seeking exemption from Experience / Turnover Criteria, the supporting documents to prove his eligibility for exemption must be uploaded for evaluation by the buyer
<b>Past Performance/विगत प्रदर्शन</b>	40 %
<b>Bid to RA enabled/बिड से रिवर्स नीलामी सक्रिय किया</b>	No
<b>Type of Bid/बिड का प्रकार</b>	Two Packet Bid
<b>Primary product category</b>	Reconditioning of indexing unit
<b>Time allowed for Technical Clarifications during technical evaluation/तकनीकी मूल्यांकन के दौरान तकनीकी स्पष्टीकरण हेतु अनुमत समय</b>	7 Days
<b>Evaluation Method/मूल्यांकन पद्धति</b>	Total value wise evaluation

**EMD Detail/ईएमडी विवरण**

Advisory Bank/एडवाइजरी बैंक	Indusind bank
EMD Amount/ईएमडी राशि	112000

**ePBG Detail/ईपीबीजी विवरण**

Advisory Bank	Indusind bank
ePBG Percentage(%) / ईपीबीजी प्रतिशत (%)	3.00
Duration of ePBG required (Months) / ईपीबीजी की अपेक्षित अवधि (महीने).	16

(a). EMD EXEMPTION: The bidder seeking EMD exemption, must submit the valid supporting document for the relevant category as per GeM GTC with the bid. Under MSE category, only manufacturers for goods and Service Providers for Services are eligible for exemption from EMD. Traders are excluded from the purview of this Policy./जेम की शर्तों के अनुसार ईएमडी छूट के इच्छुक बिडर को संबंधित केटेगरी के लिए बिड के साथ वैध समर्थित दस्तावेज़ प्रस्तुत करने हैं। एमएसई केटेगरी के अंतर्गत केवल वस्तुओं के लिए विनिर्माता तथा सेवाओं के लिए सेवा प्रदाता ईएमडी से छूट के पात्र हैं। व्यापारियों को इस नीति के दायरे से बाहर रखा गया है।

(b). EMD & Performance security should be in favour of Beneficiary, wherever it is applicable./ईएमडी और संपादन जमानत राशि, जहां यह लागू होती है, लाभार्थी के पक्ष में होनी चाहिए।

**Beneficiary/लाभार्थी :**

DGM(TO) & MATERIALS HEAD  
India Govt. Mint, Kolkata Alipore-700053  
(Nayan Sarkar)

## Splitting/विभाजन

Bid splitting not applied.

## MII Purchase Preference/एमआईआई खरीद वरीयता

MII Purchase Preference/एमआईआई खरीद वरीयता	Yes
--	-----

## MSE Purchase Preference/एमएसई खरीद वरीयता

MSE Purchase Preference/एमएसई खरीद वरीयता	Yes
---	-----

1. If the bidder is a Micro or Small Enterprise as per latest definitions under MSME rules, the bidder shall be exempted from the requirement of "Bidder Turnover" criteria and "Experience Criteria" subject to meeting of quality and technical specifications. If the bidder is OEM of the offered products, it would be exempted from the "OEM Average Turnover" criteria also subject to meeting of quality and technical specifications. In case any bidder is seeking exemption from Turnover / Experience Criteria, the supporting documents to prove his eligibility for exemption must be uploaded for evaluation by the buyer.
2. If the bidder is a Startup, the bidder shall be exempted from the requirement of "Bidder Turnover" criteria and "Experience Criteria" subject to their meeting of quality and technical specifications. If the bidder is OEM of the offered products, it would be exempted from the "OEM Average Turnover" criteria also subject to meeting of quality and technical specifications. In case any bidder is seeking exemption from Turnover / Experience Criteria, the supporting documents to prove his eligibility for exemption must be uploaded for evaluation by the buyer.
3. The minimum average annual financial turnover of the bidder during the last three years, ending on 31st March of the previous financial year, should be as indicated above in the bid document. Documentary evidence in the form of certified Audited Balance Sheets of relevant periods or a certificate from the Chartered Accountant / Cost Accountant indicating the turnover details for the relevant period shall be uploaded with the bid. In case the date of constitution / incorporation of the bidder is less than 3-year-old, the average turnover in respect of the completed financial years after the date of constitution shall be taken into account for this criteria.
4. Experience Criteria: In respect of the filter applied for experience criteria, the Bidder or its OEM {themselves or through reseller(s)} should have regularly, manufactured and supplied same or similar Category Products to any Central / State Govt Organization / PSU / Public Listed Company for number of Financial years as indicated above in the bid document before the bid opening date. Copies of relevant contracts to be submitted along with bid in support of having supplied some quantity during each of the Financial year. In case of bunch bids, the category of primary product having highest value should meet this criterion.
5. Preference to Make In India products (For bids < 200 Crore): Preference shall be given to Class 1 local supplier as defined in public procurement (Preference to Make in India), Order 2017 as amended from time to time and its subsequent Orders/Notifications issued by concerned Nodal Ministry for specific Goods/Products. The minimum local content to qualify as a Class 1 local supplier is denoted in the bid document. If the bidder wants to avail the Purchase preference, the bidder must upload a certificate from the OEM regarding the percentage of the local content and the details of locations at which the local value addition is made along with their bid, failing which no purchase preference shall be granted. In case the bid value is more than Rs 10 Crore, the declaration relating to percentage of local content shall be certified by the statutory auditor or cost auditor, if the OEM is a company and by a practicing cost accountant or a chartered accountant for OEMs other than companies as per the Public Procurement (preference to Make-in -India) order 2017 dated 04.06.2020. Only Class-I and Class-II Local suppliers as per MII order dated 4.6.2020 will be eligible to bid. Non - Local suppliers as per MII order dated 04.06.2020 are not eligible to participate. However, eligible micro and small enterprises will be allowed to participate .In case Buyer has selected Purchase preference to Micro and Small Enterprises clause in the bid, the same will get precedence over this clause.
6. Purchase preference to Micro and Small Enterprises (MSEs): Purchase preference will be given to MSEs as defined in Public Procurement Policy for Micro and Small Enterprises (MSEs) Order, 2012 dated 23.03.2012 issued by Ministry of Micro, Small and Medium Enterprises and its subsequent Orders/Notifications issued by concerned Ministry. If the bidder wants to avail the Purchase preference, the bidder must be the manufacturer of the offered product in case of bid for supply of goods. Traders are excluded from the purview of Public Procurement Policy for Micro and Small Enterprises. In respect of bid for Services, the bidder must be the Service provider of the offered Service. Relevant documentary evidence in this regard shall be uploaded along with the bid in respect of the offered product or service. If L-1 is not an MSE and MSE Seller (s) has/have quoted price within L-1+ 15%

(Selected by Buyer)of margin of purchase preference /price band defined in relevant policy, such Seller shall be given opportunity to match L-1 price and contract will be awarded for 25%(selected by Buyer) percentage of total QUANTITY.

7. Estimated Bid Value indicated above is being declared solely for the purpose of guidance on EMD amount and for determining the Eligibility Criteria related to Turn Over, Past Performance and Project / Past Experience etc. This has no relevance or bearing on the price to be quoted by the bidders and is also not going to have any impact on bid participation. Also this is not going to be used as a criteria in determining reasonableness of quoted prices which would be determined by the buyer based on its own assessment of reasonableness and based on competitive prices received in Bid / RA process.

8. Past Performance: The Bidder or its OEM {themselves or through re-seller(s)} should have supplied same or similar Category Products for 40% of bid quantity, in at least one of the last three Financial years before the bid opening date to any Central / State Govt Organization / PSU / Public Listed Company. Copies of relevant contracts (proving supply of cumulative order quantity in any one financial year) to be submitted along with bid in support of quantity supplied in the relevant Financial year. In case of bunch bids, the category related to primary product having highest bid value should meet this criterion.

### Thickness Monitor For MRH MRV 150

**(Minimum 50% and 20% Local Content required for qualifying as Class 1 and Class 2 Local Supplier respectively/क्रमशः श्रेणी 1 और श्रेणी 2 के स्थानीय आपूर्तिकर्ता के रूप में अर्हता प्राप्त करने के लिए आवश्यक)**

Brand Type/ब्रांड का प्रकार	Unbranded
-----------------------------	-----------

### Technical Specifications/तकनीकी विशिष्टियाँ

<b>Specification Document</b>	<a href="#">View File</a>
<b>BOQ Detail Document</b>	<a href="#">View File</a>

Advisory-Please refer attached BOQ document for detailed consignee list and delivery period.

### Consignees/Reporting Officer/परेषिती/रिपोर्टिंग अधिकारी and/ तथा Quantity/मात्रा

S.No./क्र. सं.	Consignee Reporting/Officer/ परेषिती/रिपोर्टिंग अधिकारी	Address/पता	Quantity/मात्रा	Delivery Days/डिलीवरी के दिन
1	Indranil Payra	700053,India Govt Mint, Alipore Kolkata , West Bengal	45	56

### Guide Piece For MRV 150

**(Minimum 50% and 20% Local Content required for qualifying as Class 1 and Class 2 Local Supplier respectively/क्रमशः श्रेणी 1 और श्रेणी 2 के स्थानीय आपूर्तिकर्ता के रूप में अर्हता प्राप्त करने के लिए आवश्यक)**

Brand Type/ब्रांड का प्रकार	Unbranded
-----------------------------	-----------

**Technical Specifications/तकनीकी विशिष्टियाँ**

<b>Specification Document</b>	<a href="#">View File</a>
<b>BOQ Detail Document</b>	<a href="#">View File</a>

Advisory-Please refer attached BOQ document for detailed consignee list and delivery period.

**Consignees/Reporting Officer/परेषिती/रिपोर्टिंग अधिकारी and/ तथा Quantity/मात्र**

<b>S.No./क्र. सं.</b>	<b>Consignee Reporting/Officer/ परेषिती/रिपोर्टिंग अधिकारी</b>	<b>Address/पता</b>	<b>Quantity/मात्र</b>	<b>Delivery Days/डिलीवरी के दिन</b>
1	Indranil Payra	700053,India Govt Mint, Alipore Kolkata , West Bengal	9	56

**Feed Chute And Nylon Insert For MRV 150**

**(Minimum 50% and 20% Local Content required for qualifying as Class 1 and Class 2 Local Supplier respectively/क्रमशः श्रेणी 1 और श्रेणी 2 के स्थानीय आपूर्तिकर्ता के रूप में अर्हता प्राप्त करने के लिए आवश्यक)**

Brand Type/ब्रांड का प्रकार	Unbranded
-----------------------------	-----------

**Technical Specifications/तकनीकी विशिष्टियाँ**

<b>Specification Document</b>	<a href="#">View File</a>
<b>BOQ Detail Document</b>	<a href="#">View File</a>

Advisory-Please refer attached BOQ document for detailed consignee list and delivery period.

**Consignees/Reporting Officer/परेषिती/रिपोर्टिंग अधिकारी and/ तथा Quantity/मात्र**

S.No./क्र. सं.	Consignee Reporting/Officer/ परेषिती/रिपोर्टिंग अधिकारी	Address/पता	Quantity/मात्रा	Delivery Days/डिलीवरी के दिन
1	Indranil Payra	700053,India Govt Mint, Alipore Kolkata , West Bengal	9	56

### Base Plate For Feed Chute For MRV 150

(Minimum 50% and 20% Local Content required for qualifying as Class 1 and Class 2 Local Supplier respectively/क्रमशः श्रेणी 1 और श्रेणी 2 के स्थानीय आपूर्तिकर्ता के रूप में अर्हता प्राप्त करने के लिए आवश्यक)

Brand Type/ब्रांड का प्रकार	Unbranded
-----------------------------	-----------

### Technical Specifications/तकनीकी विशिष्टियाँ

Specification Document	<a href="#">View File</a>
BOQ Detail Document	<a href="#">View File</a>

Advisory-Please refer attached BOQ document for detailed consignee list and delivery period.

### Consignees/Reporting Officer/परेषिती/रिपोर्टिंग अधिकारी and/ तथा Quantity/मात्रा

S.No./क्र. सं.	Consignee Reporting/Officer/ परेषिती/रिपोर्टिंग अधिकारी	Address/पता	Quantity/मात्रा	Delivery Days/डिलीवरी के दिन
1	Indranil Payra	700053,India Govt Mint, Alipore Kolkata , West Bengal	9	56

### Pusher For MRV 150

(Minimum 50% and 20% Local Content required for qualifying as Class 1 and Class 2 Local Supplier respectively/क्रमशः श्रेणी 1 और श्रेणी 2 के स्थानीय आपूर्तिकर्ता के रूप में अर्हता प्राप्त करने के लिए आवश्यक)

Brand Type/ब्रांड का प्रकार	Unbranded
-----------------------------	-----------

### Technical Specifications/तकनीकी विशिष्टियाँ

Specification Document	<a href="#">View File</a>
BOQ Detail Document	<a href="#">View File</a>

Advisory-Please refer attached BOQ document for detailed consignee list and delivery period.

**Consignees/Reporting Officer/परेषिती/रिपोर्टिंग अधिकारी and/ तथा Quantity/मात्र**

S.No./क्र. सं.	Consignee Reporting/Officer/ परेषिती/रिपोर्टिंग अधिकारी	Address/पता	Quantity/मात्र	Delivery Days/डिलीवरी के दिन
1	Indranil Payra	700053,India Govt Mint, Alipore Kolkata , West Bengal	18	56

**Segment For MRV Coining Press**

**(Minimum 50% and 20% Local Content required for qualifying as Class 1 and Class 2 Local Supplier respectively/क्रमशः श्रेणी 1 और श्रेणी 2 के स्थानीय आपूर्तिकर्ता के रूप में अर्हता प्राप्त करने के लिए आवश्यक)**

Brand Type/ब्रांड का प्रकार	Unbranded
-----------------------------	-----------

**Technical Specifications/तकनीकी विशिष्टियाँ**

Specification Document	<a href="#">View File</a>
BOQ Detail Document	<a href="#">View File</a>

Advisory-Please refer attached BOQ document for detailed consignee list and delivery period.

**Consignees/Reporting Officer/परेषिती/रिपोर्टिंग अधिकारी and/ तथा Quantity/मात्र**

S.No./क्र. सं.	Consignee Reporting/Officer/ परेषिती/रिपोर्टिंग अधिकारी	Address/पता	Quantity/मात्र	Delivery Days/डिलीवरी के दिन
1	Indranil Payra	700053,India Govt Mint, Alipore Kolkata , West Bengal	9	56

**Coin Plate A For MRH 150**

**(Minimum 50% and 20% Local Content required for qualifying as Class 1 and Class 2 Local Supplier respectively/क्रमशः श्रेणी 1 और श्रेणी 2 के स्थानीय आपूर्तिकर्ता के रूप में अर्हता प्राप्त करने के लिए आवश्यक)**

Brand Type/ब्रांड का प्रकार	Unbranded
-----------------------------	-----------

**Technical Specifications/तकनीकी विशिष्टियाँ**

<b>Specification Document</b>	<a href="#">View File</a>
<b>BOQ Detail Document</b>	<a href="#">View File</a>

Advisory-Please refer attached BOQ document for detailed consignee list and delivery period.

**Consignees/Reporting Officer/परेषिती/रिपोर्टिंग अधिकारी and/ तथा Quantity/मात्रा**

S.No./क्र. सं.	Consignee Reporting/Officer/ परेषिती/रिपोर्टिंग अधिकारी	Address/पता	Quantity/मात्रा	Delivery Days/डिलीवरी के दिन
1	Indranil Payra	700053,India Govt Mint, Alipore Kolkata , West Bengal	30	56

**Coin Plate B For MRH 150**

**(Minimum 50% and 20% Local Content required for qualifying as Class 1 and Class 2 Local Supplier respectively/क्रमशः श्रेणी 1 और श्रेणी 2 के स्थानीय आपूर्तिकर्ता के रूप में अर्हता प्राप्त करने के लिए आवश्यक)**

Brand Type/ब्रांड का प्रकार	Unbranded
-----------------------------	-----------

**Technical Specifications/तकनीकी विशिष्टियाँ**

<b>Specification Document</b>	<a href="#">View File</a>
<b>BOQ Detail Document</b>	<a href="#">View File</a>

Advisory-Please refer attached BOQ document for detailed consignee list and delivery period.



**Consignees/Reporting Officer/परेषिती/रिपोर्टिंग अधिकारी and/ तथा Quantity/मात्रा**

S.No./क्र. सं.	Consignee Reporting/Officer/ परेषिती/रिपोर्टिंग अधिकारी	Address/पता	Quantity/मात्रा	Delivery Days/डिलीवरी के दिन
1	Indranil Payra	700053,India Govt Mint, Alipore Kolkata , West Bengal	30	56

**Swing Plate Assembly For MRH 150**

(Minimum 50% and 20% Local Content required for qualifying as Class 1 and Class 2 Local Supplier respectively/क्रमशः श्रेणी 1 और श्रेणी 2 के स्थानीय आपूर्तिकर्ता के रूप में अर्हता प्राप्त करने के लिए आवश्यक)

Brand Type/ब्रांड का प्रकार	Unbranded
-----------------------------	-----------

**Technical Specifications/तकनीकी विशिष्टियाँ**

Specification Document	<a href="#">View File</a>
BOQ Detail Document	<a href="#">View File</a>

Advisory-Please refer attached BOQ document for detailed consignee list and delivery period.

**Consignees/Reporting Officer/परेषिती/रिपोर्टिंग अधिकारी and/ तथा Quantity/मात्रा**

S.No./क्र. सं.	Consignee Reporting/Officer/ परेषिती/रिपोर्टिंग अधिकारी	Address/पता	Quantity/मात्रा	Delivery Days/डिलीवरी के दिन
1	Indranil Payra	700053,India Govt Mint, Alipore Kolkata , West Bengal	10	56

**Coin Discharge Conveyor**

(Minimum 50% and 20% Local Content required for qualifying as Class 1 and Class 2 Local Supplier respectively/क्रमशः श्रेणी 1 और श्रेणी 2 के स्थानीय आपूर्तिकर्ता के रूप में अर्हता प्राप्त करने के लिए आवश्यक)

Brand Type/ब्रांड का प्रकार	Unbranded
-----------------------------	-----------

**Technical Specifications/तकनीकी विशिष्टियाँ**

Specification Document	<a href="#">View File</a>
------------------------	---------------------------

**BOQ Detail Document**[View File](#)

Advisory-Please refer attached BOQ document for detailed consignee list and delivery period.

**Consignees/Reporting Officer/परेषिती/रिपोर्टिंग अधिकारी and/ तथा Quantity/मात्र**

S.No./क्र. सं.	Consignee Reporting/Officer/ परेषिती/रिपोर्टिंग अधिकारी	Address/पता	Quantity/मात्र	Delivery Days/डिलीवरी के दिन
1	Indranil Payra	700053,India Govt Mint, Alipore Kolkata , West Bengal	3	56

**Toggle Clamps 225U**

(Minimum 50% and 20% Local Content required for qualifying as Class 1 and Class 2 Local Supplier respectively/क्रमशः श्रेणी 1 और श्रेणी 2 के स्थानीय आपूर्तिकर्ता के रूप में अर्हता प्राप्त करने के लिए आवश्यक)

Brand Type/ब्रांड का प्रकार	Unbranded
-----------------------------	-----------

**Technical Specifications/तकनीकी विशिष्टियाँ**

<b>Specification Document</b>	<a href="#">View File</a>
<b>BOQ Detail Document</b>	<a href="#">View File</a>

Advisory-Please refer attached BOQ document for detailed consignee list and delivery period.

**Consignees/Reporting Officer/परेषिती/रिपोर्टिंग अधिकारी and/ तथा Quantity/मात्र**

S.No./क्र. सं.	Consignee Reporting/Officer/ परेषिती/रिपोर्टिंग अधिकारी	Address/पता	Quantity/मात्र	Delivery Days/डिलीवरी के दिन
----------------	---	-------------	----------------	------------------------------

S.No./क्र. सं.	Consignee Reporting/Officer/ परेषिती/रिपोर्टिंग अधिकारी	Address/पता	Quantity/मात्रा	Delivery Days/डिलीवरी के दिन
1	Indranil Payra	700053,India Govt Mint, Alipore Kolkata , West Bengal	24	56

### Toggle Clamps 210U

(Minimum 50% and 20% Local Content required for qualifying as Class 1 and Class 2 Local Supplier respectively/क्रमशः श्रेणी 1 और श्रेणी 2 के स्थानीय आपूर्तिकर्ता के रूप में अर्हता प्राप्त करने के लिए आवश्यक)

Brand Type/ब्रांड का प्रकार	Unbranded
-----------------------------	-----------

### Technical Specifications/तकनीकी विशिष्टियाँ

Specification Document	<a href="#">View File</a>
BOQ Detail Document	<a href="#">View File</a>

Advisory-Please refer attached BOQ document for detailed consignee list and delivery period.

### Consignees/Reporting Officer/परेषिती/रिपोर्टिंग अधिकारी and/ तथा Quantity/मात्रा

S.No./क्र. सं.	Consignee Reporting/Officer/ परेषिती/रिपोर्टिंग अधिकारी	Address/पता	Quantity/मात्रा	Delivery Days/डिलीवरी के दिन
1	Indranil Payra	700053,India Govt Mint, Alipore Kolkata , West Bengal	24	56

### Toggle Clamps 207U

(Minimum 50% and 20% Local Content required for qualifying as Class 1 and Class 2 Local Supplier respectively/क्रमशः श्रेणी 1 और श्रेणी 2 के स्थानीय आपूर्तिकर्ता के रूप में अर्हता प्राप्त करने के लिए आवश्यक)

Brand Type/ब्रांड का प्रकार	Unbranded
-----------------------------	-----------

### Technical Specifications/तकनीकी विशिष्टियाँ

Specification Document	<a href="#">View File</a>
BOQ Detail Document	<a href="#">View File</a>

Advisory-Please refer attached BOQ document for detailed consignee list and delivery period.

**Consignees/Reporting Officer/परेषिती/रिपोर्टिंग अधिकारी and/ तथा Quantity/मात्र**

S.No./क्र. सं.	Consignee Reporting/Officer/ परेषिती/रिपोर्टिंग अधिकारी	Address/पता	Quantity/मात्र	Delivery Days/डिलीवरी के दिन
1	Indranil Payra	700053,India Govt Mint, Alipore Kolkata , West Bengal	24	56

**Toggle Clamps 201U**

**(Minimum 50% and 20% Local Content required for qualifying as Class 1 and Class 2 Local Supplier respectively/क्रमशः श्रेणी 1 और श्रेणी 2 के स्थानीय आपूर्तिकर्ता के रूप में अर्हता प्राप्त करने के लिए आवश्यक)**

Brand Type/ब्रांड का प्रकार	Unbranded
-----------------------------	-----------

**Technical Specifications/तकनीकी विशिष्टियाँ**

Specification Document	<a href="#">View File</a>
BOQ Detail Document	<a href="#">View File</a>

Advisory-Please refer attached BOQ document for detailed consignee list and delivery period.

**Consignees/Reporting Officer/परेषिती/रिपोर्टिंग अधिकारी and/ तथा Quantity/मात्र**

S.No./क्र. सं.	Consignee Reporting/Officer/ परेषिती/रिपोर्टिंग अधिकारी	Address/पता	Quantity/मात्र	Delivery Days/डिलीवरी के दिन
1	Indranil Payra	700053,India Govt Mint, Alipore Kolkata , West Bengal	24	56

**Sprocket For Coin Blank Conveyor**

**(Minimum 50% and 20% Local Content required for qualifying as Class 1 and Class 2 Local Supplier respectively/क्रमशः श्रेणी 1 और श्रेणी 2 के स्थानीय आपूर्तिकर्ता के रूप में अर्हता प्राप्त करने के लिए आवश्यक)**

Brand Type/ब्रांड का प्रकार	Unbranded
-----------------------------	-----------

**Technical Specifications/तकनीकी विशिष्टियाँ**

<b>Specification Document</b>	<a href="#">View File</a>
<b>BOQ Detail Document</b>	<a href="#">View File</a>

Advisory-Please refer attached BOQ document for detailed consignee list and delivery period.

**Consignees/Reporting Officer/परेषिती/रिपोर्टिंग अधिकारी and/ तथा Quantity/मात्रा**

S.No./क्र. सं.	Consignee Reporting/Officer/ परेषिती/रिपोर्टिंग अधिकारी	Address/पता	Quantity/मात्रा	Delivery Days/डिलीवरी के दिन
1	Indranil Payra	700053,India Govt Mint, Alipore Kolkata , West Bengal	24	56

**Collar Switch Assy For MRH 150**

**(Minimum 50% and 20% Local Content required for qualifying as Class 1 and Class 2 Local Supplier respectively/क्रमशः श्रेणी 1 और श्रेणी 2 के स्थानीय आपूर्तिकर्ता के रूप में अर्हता प्राप्त करने के लिए आवश्यक)**

Brand Type/ब्रांड का प्रकार	Unbranded
-----------------------------	-----------

**Technical Specifications/तकनीकी विशिष्टियाँ**

<b>Specification Document</b>	<a href="#">View File</a>
<b>BOQ Detail Document</b>	<a href="#">View File</a>

Advisory-Please refer attached BOQ document for detailed consignee list and delivery period.

**Consignees/Reporting Officer/परेषिती/रिपोर्टिंग अधिकारी and/ तथा Quantity/मात्रा**

S.No./क्र. सं.	Consignee Reporting/Officer/ परेषिती/रिपोर्टिंग अधिकारी	Address/पता	Quantity/मात्रा	Delivery Days/डिलीवरी के दिन
1	Indranil Payra	700053,India Govt Mint, Alipore Kolkata , West Bengal	15	56

**Collar Switch Assy For MRV 150**

(Minimum 50% and 20% Local Content required for qualifying as Class 1 and Class 2 Local Supplier respectively/क्रमशः श्रेणी 1 और श्रेणी 2 के स्थानीय आपूर्तिकर्ता के रूप में अर्हता प्राप्त करने के लिए आवश्यक)

Brand Type/ब्रांड का प्रकार	Unbranded
-----------------------------	-----------

**Technical Specifications/तकनीकी विशिष्टियाँ**

Specification Document	<a href="#">View File</a>
BOQ Detail Document	<a href="#">View File</a>

Advisory-Please refer attached BOQ document for detailed consignee list and delivery period.

**Consignees/Reporting Officer/परेषिती/रिपोर्टिंग अधिकारी and/ तथा Quantity/मात्रा**

S.No./क्र. सं.	Consignee Reporting/Officer/ परेषिती/रिपोर्टिंग अधिकारी	Address/पता	Quantity/मात्रा	Delivery Days/डिलीवरी के दिन
1	Indranil Payra	700053,India Govt Mint, Alipore Kolkata , West Bengal	3	56

**FOUNDATION SPRING SCHULER PRESS**

(Minimum 50% and 20% Local Content required for qualifying as Class 1 and Class 2 Local Supplier respectively/क्रमशः श्रेणी 1 और श्रेणी 2 के स्थानीय आपूर्तिकर्ता के रूप में अर्हता प्राप्त करने के लिए आवश्यक)

Brand Type/ब्रांड का प्रकार	Unbranded
-----------------------------	-----------

**Technical Specifications/तकनीकी विशिष्टियाँ**

Specification Document	<a href="#">View File</a>
------------------------	---------------------------

**BOQ Detail Document**[View File](#)

Advisory-Please refer attached BOQ document for detailed consignee list and delivery period.

**Consignees/Reporting Officer/परेषिती/रिपोर्टिंग अधिकारी and/ तथा Quantity/मात्र**

S.No./क्र. सं.	Consignee Reporting/Officer/ परेषिती/रिपोर्टिंग अधिकारी	Address/पता	Quantity/मात्र	Delivery Days/डिलीवरी के दिन
1	Indranil Payra	700053,India Govt Mint, Alipore Kolkata , West Bengal	200	56

**Reconditioning Of Indexing Unit**

(Minimum 50% and 20% Local Content required for qualifying as Class 1 and Class 2 Local Supplier respectively/क्रमशः श्रेणी 1 और श्रेणी 2 के स्थानीय आपूर्तिकर्ता के रूप में अर्हता प्राप्त करने के लिए आवश्यक)

Brand Type/ब्रांड का प्रकार	Unbranded
-----------------------------	-----------

**Technical Specifications/तकनीकी विशिष्टियाँ**

<b>Specification Document</b>	<a href="#">View File</a>
<b>BOQ Detail Document</b>	<a href="#">View File</a>

Advisory-Please refer attached BOQ document for detailed consignee list and delivery period.

**Consignees/Reporting Officer/परेषिती/रिपोर्टिंग अधिकारी and/ तथा Quantity/मात्र**

S.No./क्र. सं.	Consignee Reporting/Officer/ परेषिती/रिपोर्टिंग अधिकारी	Address/पता	Quantity/मात्र	Delivery Days/डिलीवरी के दिन
----------------	---	-------------	----------------	------------------------------

S.No./क्र. सं.	Consignee Reporting/Officer/ परेषिती/रिपोर्टिंग अधिकारी	Address/पता	Quantity/मात्रा	Delivery Days/डिलीवरी के दिन
1	Indranil Payra	700053,India Govt Mint, Alipore Kolkata , West Bengal	7	56

## Buyer Added Bid Specific Terms and Conditions/क्रेता द्वारा जोड़ी गई बिड की विशेष शर्तें

### 1. Generic

OPTION CLAUSE: The Purchaser reserves the right to increase or decrease the quantity to be ordered up to 25 percent of bid quantity at the time of placement of contract. The purchaser also reserves the right to increase the ordered quantity by up to 25% of the contracted quantity during the currency of the contract at the contracted rates. Bidders are bound to accept the orders accordingly.

### 2. Generic

Bidders are advised to check applicable GST on their own before quoting. Buyer will not take any responsibility in this regards. GST reimbursement will be as per actuals or as per applicable rates (whichever is lower), subject to the maximum of quoted GST %.

### 3. Generic

#### OPTIONAL SITE VISIT:

1. The Bidder is advised to visit and examine the installation site and its surroundings and obtain for itself on its own responsibility all information that may be necessary for preparing the Bid. The costs of visiting the site shall be borne by the Bidder. itself

2. The Bidder representative shall be allowed entry upon consignee premises for such visits, only upon the express conditions that the Bidder will release and indemnify the Buyer and Consignee against all liabilities arising out of such visit including death or injury, loss or damage to property, and any other loss, damage, costs, and expenses incurred as a result of such visit.

3. The Bidder shall not be entitled to hold any claim against Buyer for noncompliance due to lack of any kind of pre-requisite information as it is the sole responsibility of the Bidder to obtain all the necessary information with regard to site, surrounding, working conditions, weather etc. on its own before submission of the bid.

### 4. Forms of EMD and PBG

Bidders can also submit the EMD with Account Payee Demand Draft in favour of India Govt. Mint payable at Kolkata.

Bidder has to upload scanned copy / proof of the DD along with bid and has to ensure delivery of hardcopy to the Buyer within 5 days of Bid End date / Bid Opening date.

### 5. Forms of EMD and PBG

Bidders can also submit the EMD with Fixed Deposit Receipt made out or pledged in the name of A/C (Name of the Buyer). The bank should certify on it that the deposit can be withdrawn only on the demand or with the sanction of the pledgee. For release of EMD, the FDR will be released in the favour of the bidder by the Buyer after making endorsement on the back of the FDR duly signed and stamped along with covering letter. Bidder has to upload scanned copy/ proof of the FDR along with bid and has to ensure delivery of hardcopy to the Buyer within 5 days of Bid End date/ Bid Opening date

### 6. Forms of EMD and PBG

Bidders can also submit the EMD with Banker's Cheque in favour of India Govt. Mint payable at Kolkata.



Bidder has to upload scanned copy / proof of the BC along with bid and has to ensure delivery of hardcopy to the Buyer within 5 days of Bid End date / Bid Opening date.

#### 7. **Forms of EMD and PBG**

Successful Bidder can submit the Performance Security in the form of Account Payee Demand Draft also (besides PBG which is allowed as per GeM GTC). DD should be made in favour of India Govt. Mint payable at Kolkata. After award of contract, Successful Bidder can upload scanned copy of the DD in place of PBG and has to ensure delivery of hard copy to the original DD to the Buyer within 15 days of award of contract.

#### 8. **Forms of EMD and PBG**

Successful Bidder can submit the Performance Security in the form of Fixed Deposit Receipt also (besides PBG which is allowed as per GeM GTC). FDR should be made out or pledged in the name of India Govt. Mint, Kolkata A/C (Name of the Seller). The bank should certify on it that the deposit can be withdrawn only on the demand or with the sanction of the pledgee. For release of Security Deposit, the FDR will be released in favour of bidder by the Buyer after making endorsement on the back of the FDR duly signed and stamped along with covering letter. Successful Bidder has to upload scanned copy of the FDR document in place of PBG and has to ensure delivery of hard copy of Original FDR to the Buyer within 15 days of award of contract.

#### 9. **Buyer Added Bid Specific ATC**

Buyer Added text based ATC clauses

##### **1. Eligible Goods and Services (Origin of Goods):**

(i) All goods and services to be supplied and provided for the contract shall have the origin in India or in the countries with which the Government of India has trade relations. (ii) The word "origin" incorporated in this clause means the place from where the goods are mines, cultivated, grown, manufactured, produced or processed or from where the service are arranged.

**2. Special Condition:** Supplier should file the returns pertaining to TCS (Section 206C (1H) for TCS collected, in the time and provide the TCS certificate to IGMK. In case of any Credit loss to IGMK by way of their failure to files Returns and provide TCS certificate in time, India Government Mint, Kolkata reserves the right to recover the amount equivalent to TCS paid along with applicable interest from the payment of further supplies.

##### **3. GST Return:**

Supplier should file the GST return for outward supplies in time. In case of any loss to India Government Mint, Kolkata by way of their failure to files GST Returns in time India Government Mint, Kolkata reserves the right to withhold the payment of further supplies till production of evidence. Any liability which will occurred on account of non - compliance of e-way bill, GST provision or any other applicable law will be borne by supplier.

##### **4. Consignee:**

Chief General Manager, India Government Mint, Alipore, Kolkata

**On the consignment please mention the following details:**

Order No :                      Packing No :                      Net Weight :                      Gross Weight :

**5. Packing:**

Items should be suitably packed. The packing should be weather proof and should be made water proof to prevent damage during transit. The supplier will also be responsible for unloading and stacking at Mint Store as per instruction of competent authority.

**6. Delivery Period:**

Within 8 weeks from the date of issue of India Govt. Mint, Kolkata Purchase Order

**7. Terms and Mode of payments:**

100% payment on receipt and acceptance of goods by the user section and on production of all required documents by the supplier.

**8. Transportation of Domestic Goods:**

To be borne by the supplier.

**9. Warranty:**

This warranty shall remain valid for TWELVE months after the goods or any portion thereof as the case may be, have been delivered to the final destination and installed and commissioned at the final destination and accepted by India Govt. Mint, Kolkata in terms of the contract. The supplier warrants that the goods supplied under the contract is new, unused, and incorporate all recent improvements in design and materials unless prescribed otherwise by India Govt. Mint, Kolkata in the contract. The supplier further warrants that the goods supplied under the contract shall have no defect arising from design, or workmanship or from any act or omission of the supplier, that may develop under normal use of the supplied goods under the conditions prevailing in India.

**10. Insurance:**

The supplier shall make arrangements for insuring the goods against loss or damage incidental to manufacture or acquisition, transportation, storage and deliver as per bear by firm.

**11. Quantum of LD:**

If the supplier fails to deliver any or all of the goods or fails to perform the services within the time frame(s) incorporated in the contract, India Govt. Mint, Kolkata shall, without prejudice to other rights and remedies available to India Govt. Mint, Kolkata under the contract, deduct from the contract price, as liquidated damages, a sum equivalent to the 0.5% of the delivered price of the delayed goods and/or services for each week of delay or part thereof until actual delivery or performance, subject to a maximum deduction of the 10% of the delayed goods' or services' contract price(s).

**12. Resolution of Disputes:**

If dispute or difference of any kind shall arise between India Government Mint, Kolkata and the supplier in connection with or relating the contract, the parties shall make every effort to resolve the same amicably by mutual consultations. If the parties fail to resolve the same amicably the mutual consultations. If the parties fail to resolve their dispute or difference by such mutual consultation within 21 days of its occurrence, then, unless otherwise provided in the SCC, either India Government Mint, Kolkata or the supplier may seek recourse to settlement of disputes through arbitration act 33.2. Disputes arising out of any breach of contract pertaining to this tender shall be settled in the court of competent

jurisdiction located within Kolkata only.

### **13. Risk Purchase Clause :**

(a) If the supplier after submission of tender and due acceptance of the same, i.e. after notification of award of contract fails to abide by the terms and conditions of these tender documents, or fails to supply the deliverables as per delivery schedule given or at any time repudiates the contract, the purchaser shall have the right to:

(i) Invoke the Security-cum-Performance Guarantee if deposited by the supplier and procure stores from other agencies at the risk and consequence of the supplier. The cost difference between the alternative arrangement and supplier tendered value will be recovered from the supplier.

(b) Supplier has to abide by all the terms and conditions of tender.

(c) In case of procurement through alternative sources and if procurement price is lower, no benefit on this account will be passed on to the supplier.

**14.** The total cost inclusive of all as cited above on FOR India Govt. Mint, Kolkata (W.B) basis should be indicated clearly both in words and figures in the price bid.

### **15. Quality Control Requirements:**

Quality of all item/service: Free from all technical defects, in compliance with our Technical Specification

i) Goods/service supplied not in conformity with tender specification will be treated as goods/service not supplied at all and supplier shall take supplied material not confirming to order specification back within 15 days. Goods/service shall be delivered by the supplier in accordance with the terms and conditions specified in the contract failing which expenses of keeping goods at purchaser's premises may be levied on supplier.

ii) Delivery date will be calculated from the date goods/services are received in acceptable quality in accordance with technical specification.

**16.** Purchaser reserves the right to reject all or any of the Bidders or Bids or to decide to drop the procurement process at any stage without assigning any reason.

### **17. MSME & Make in India Status:**

In case any bidder is submitting their bid as MSME and/or MII, the firm must be registered as a MSME & MII in GeM portal and Self-declaration along with documentary evidence in this regard must be submitted declaring that their MSME & MII status is updated in GeM portal also. In further evaluation stage if it is found that the firm is not registered as MSME and/or MII in GeM, but MSME certificate and/or MII declaration is submitted along with the bid, no exemption will be given and their offer may be rejected.

### **18. Upload Manufacturer Authorization:**

Wherever Authorised Distributors are submitting the bid, Manufacturers Authorisation Form (MAF)/Certificate with OEM details required to be furnished along with the bid in the format provided in **Annexure- I** under Specification document .

### **19. The bidder should meet the following qualification criteria:**

**EXPERIENCE & PAST PERFORMANCE** : The bidder (manufacturer or principal of authorised representative - hereinafter referred simply as 'The Bidder') should have manufactured and supplied at least 205 numbers of similar types of spares as per Section VII : Technical Specifications in any one of the last five years ending on 31.03.2022.

IN SUPPORT OF EXPERIENCE & PAST PERFORMANCE, COPY OF PURCHASE ORDER/SUPPLY/ WORK ORDER; RESPECTIVE COMPLETION CERTIFICATE (FROM THE BUYER OF THE ITEM) AND CONTACT DETAILS(FROM THE BUYER OF THE ITEM) TO BE ENCLOSED ALONG WITH THE TENDER.

**CAPABILITY - EQUIPMENT & MANUFACTURING FACILITIES** : The bidder must have an annual capacity to manufacture and supply at least 205 numbers of similar types of spares as per Section VII : Technical Specifications.

IN SUPPORT OF THE CAPABILITY THE BIDDER HAS TO SUBMIT COPY OF SUPPORTING DOCUMENTS i.e. DETAILS OF EQUIPMENT AND MANUFACTURING FACILITIES, ENGINEERS/MANAGERS DETAILS, NUMBER OF SKILLED LABORS AVAILABLE WITH THE FIRM, ETC.

NOTE: FOR VERIFYING THE CAPABILITY/CAPACITY, IGM, KOLKATA RESERVES THE RIGHT TO DEPUTE ITS AUTHORISED REPRESENTATIVES AT THE WORKSITES.IN THE EVENT, THE FIRM IS FOUND NOT HAVING CAPABILITY/CAPACITY, THEIR OFFER IS LIABLE TO BE REJECTED

**FINANCIAL STANDING :**

a) The average annual financial turnover of the bidder during the last three years, ending on 31.03.2022, should be at least Rs. 22.33 Lakh as per the annual report (audited balance sheet and profit & loss account) of the relevant period, duly authenticated by a Chartered Accountant/Cost Accountant in India.

b) The bidder should not have suffered any financial loss for more than one year during the last three years, ending on 31.03.2022.

c)

i) The net worth of the Bidder should not be negative on 31.03.2022 and also

ii) should not have eroded by more than 30% in the last three years, ending on 31.03.2022.

SUPPORTING DOCUMENTS TO BE FURNISHED AS CLAIM AGAINST THE ABOVE ELIGIBILITY CRITERIA: ALL FINANCIAL STANDING DATA SHOULD BE CERTIFIED

BY CERTIFIED ACCOUNTANTS e.g. CHARTERED ACCOUNTANTS (CA) IN INDIA.

NOTE: BIDDER TO FURNISH STIPULATED DOCUMENTS IN SUPPORT OF FULFILLMENT OF ABOVE QUALIFYING CRITERIA i.e. EXPERIENCE & PAST PERFORMANCE, CAPABILITY AND FINANCIAL STANDING.

NON-SUBMISSION OR INCOMPLETE SUBMISSION OF DOCUMENTS MAY LEAD TO REJECTION OF OFFER.

**Note:**

All the copies of the tender shall be duly signed at the appropriate places as indicated in the bid documents and all other pages of the bid including printed literature, if any shall be initialled by the same person(s) signing the bid document. The bid document shall not contain any erasure or overwriting, except as necessary to correct any error made by the tenderer and, if there is any such correction; the same shall be initialled by the person(s) signing the tender.

**\*FOR ANY OTHER QUERIES, FIRMS MAY CONTACT IN THE BELOW DETAILS:**

**Ph. No. 033 - 2401 4132,33,34,35, (Extension 336/ 319/ 326);**

**Email: [purchase.igmk@spmcil.com](mailto:purchase.igmk@spmcil.com)**

## **Disclaimer/अस्वीकरण**

The additional terms and conditions have been incorporated by the Buyer after approval of the Competent Authority in Buyer Organization, whereby Buyer organization is solely responsible for the impact of these clauses on the bidding process, its outcome, and consequences thereof including any eccentricity / restriction arising in the bidding process due to these ATCs and due to modification of technical specifications and / or terms and conditions governing the bid. Any clause(s) incorporated by the Buyer regarding following shall be treated as null and void and would not be considered as part of bid:-

1. Definition of Class I and Class II suppliers in the bid not in line with the extant Order / Office Memorandum issued by DPIIT in this regard.
2. Seeking EMD submission from bidder(s), including via Additional Terms & Conditions, in contravention to exemption provided to such sellers under GeM GTC.
3. Publishing Custom / BOQ bids for items for which regular GeM categories are available without any Category item bunched with it.
4. Creating BoQ bid for single item.
5. Mentioning specific Brand or Make or Model or Manufacturer or Dealer name.
6. Mandating submission of documents in physical form as a pre-requisite to qualify bidders.
7. Floating / creation of work contracts as Custom Bids in Services.
8. Seeking sample with bid or approval of samples during bid evaluation process.
9. Mandating foreign / international certifications even in case of existence of Indian Standards without specifying equivalent Indian Certification / standards.
10. Seeking experience from specific organization / department / institute only or from foreign / export experience.
11. Creating bid for items from irrelevant categories.
12. Incorporating any clause against the MSME policy and Preference to Make in India Policy.
13. Reference of conditions published on any external site or reference to external documents/clauses.
14. Asking for any Tender fee / Bid Participation fee / Auction fee in case of Bids / Forward Auction, as the

case may be.

Further, if any seller has any objection/grievance against these additional clauses or otherwise on any aspect of this bid, they can raise their representation against the same by using the Representation window provided in the bid details field in Seller dashboard after logging in as a seller within 4 days of bid publication on GeM. Buyer is duty bound to reply to all such representations and would not be allowed to open bids if he fails to reply to such representations.

[This Bid is also governed by the General Terms and Conditions/ यह बिड सामान्य शर्तों के अंतर्गत भी शासित है](#)

In terms of GeM GTC clause 26 regarding Restrictions on procurement from a bidder of a country which shares a land border with India, any bidder from a country which shares a land border with India will be eligible to bid in this tender only if the bidder is registered with the Competent Authority. While participating in bid, Bidder has to undertake compliance of this and any false declaration and non-compliance of this would be a ground for immediate termination of the contract and further legal action in accordance with the laws./जेम की सामान्य शर्तों के खंड 26 के संदर्भ में भारत के साथ भूमि सीमा साझा करने वाले देश के बिडर से खरीद पर प्रतिबंध के संबंध में भारत के साथ भूमि सीमा साझा करने वाले देश का कोई भी बिडर इस निविदा में बिड देने के लिए तभी पात्र होगा जब वह बिड देने वाला सक्षम प्राधिकारी के पास पंजीकृत हो। बिड में भाग लेते समय बिडर को इसका अनुपालन करना होगा और कोई भी गलत घोषणा किए जाने व इसका अनुपालन न करने पर अनुबंध को तत्काल समाप्त करने और कानून के अनुसार आगे की कानूनी कार्रवाई का आधार होगा।

**---Thank You/धन्यवाद---**

## Technical Specifications

### 1. Thickness monitor for MRH, MRV-150

As per Mint Drawing no. H/458

Material: D2, Hardness: 60±2 HRc 15 nos. each for Rs. 2, Rs.5 and Rs. 10

Material test report to be submitted at the time of supply.

Quantity : 45 numbers

Note: 1. Sample of item will be issued on Returnable Gate Pass, if required by the firm who get the Purchase Order for the period of 1 month.

### 2. Guide piece for MRV-150

As per Mint Drawing no. H/459

Material: D2, Hardness: 60±2 HRc 3 nos. each for Rs. 2, Rs.5 and Rs. 10

Material test report to be submitted at the time of supply.

Quantity : 9 numbers

Note: 1. Sample of item will be issued on Returnable Gate Pass, if required by the firm who get the Purchase Order for the period of 1 month.

### 3. Feed chute and Nylon insert for MRV-150

Nylon insert/side support as per Mint Drawing no. H/460 (Material: Nylon) and Feed chute as per Drawing no. H/461 (Material: D2, Hardness: 60±2 HRc) 3 numbers each for Rs. 2, Rs.5 and Rs. 10

Material test report to be submitted at the time of supply.

Quantity : 9 numbers

Note: 1. Sample of item will be issued on Returnable Gate Pass, if required by the firm who get the Purchase Order for the period of 1 month.

### 4. Base Plate for feed chute for MRV-150

As per Drawing no. H/462 (Material: D2, Hardness: 60±2 HRc) 3 nos. each for Rs. 2, Rs.5 and Rs. 10

Material test report to be submitted at the time of supply.

Quantity : 9 numbers

Note: 1. Sample of item will be issued on Returnable Gate Pass, if required by the firm who get the Purchase Order for the period of 1 month.

### 5. Pusher for MRV-150

As per Drawing no. H/463 (Material: D2, Hardness: 60±2 HRc) 6 numbers each for Rs. 2, Rs.5 and Rs. 10

Material test report to be submitted at the time of supply.

Quantity : 18 numbers

Note: 1. Sample of item will be issued on Returnable Gate Pass, if required by the firm who get the Purchase Order for the period of 1 month.

### 6. Segment for MRV coining press

Denomination change part(3 piece set) for MRV-150

As per Drawing no. H/464 (Material: D2, Hardness: 60±2 HRc) 3 numbers each for Rs. 2, Rs.5 and Rs. 10

Material test report to be submitted at the time of supply.

Quantity : 9 numbers

Note: 1. Sample of item will be issued on Returnable Gate Pass, if required by the firm who get the Purchase Order for the period of 1 month.

7. Coin plate A for MRH-150

As per Drawing no. H/466 (Material: D2, Hardness: 60±2 HRc) 10 nos. each for Rs. 2, Rs.5 and Rs. 10  
Material test report to be submitted at the time of supply.

Quantity : 30 numbers

Note: 1. Sample of item will be issued on Returnable Gate Pass, if required by the firm who get the Purchase Order for the period of 1 month.

8. Coin plate B for MRH-150

As per Drawing no. H/467 (Material: D2, Hardness: 60±2 HRc) 10 nos. each for Rs. 2, Rs.5 and Rs. 10  
Material test report to be submitted at the time of supply.

Quantity : 30 numbers

Note: 1. Sample of item will be issued on Returnable Gate Pass, if required by the firm who get the Purchase Order for the period of 1 month.

9. Swing plate assembly for MRH-150

Mint Drawing no.H/ 472 for reference.

Firm may visit IGMK and see the sample before submitting tender.

Material composition: As per attached report, Hardness: 10 HRc

Material test report to be submitted at the time of supply.

Quantity : 10 numbers

Note: 1. Sample of item will be issued on Returnable Gate Pass, if required by the firm who get the Purchase Order for the period of 1 month.

10. Coin Discharge Conveyor

Quantity : 3 Each

Conveyor type FP120 with the following specifications:

Axis-center distance: 2290 mm

Belt width: 50 mm

Belt material: FNI-5E accumulation

Motor position: End of belt

Side guides: without

Belt strain: 20 kg

Roller diameter: 52 mm

Belt speed: 5m/min(constant)

Motor: Three-phase current-worm gear motor SN5FR

Performance: 90 watt

Motor rotation speed: 1350 U/min

Gear transmission ration: 50:1

Power input: 0.37/0.64 A

Nominal voltage: 400 230V 50 Hz

Protective system: IP54

Finishing: RAL 9005 jet-black

Flange version threaded hole in RNA standard execution.

Belt frame: Aluminium profile, anodized

Motor: RAL9005 black

Motor plate: RAL9006 white-aluminium

Finish plate: RAL9006 white-aluminium

11. Toggle Clamps 225U

Quantity : 24 numbers



Note: 1. Sample of item will be issued on Returnable Gate Pass, if required by the firm who get the Purchase Order for the period of 1 month.

12. Toggle Clamps 210U  
Quantity : 24 numbers

Note: 1. Sample of item will be issued on Returnable Gate Pass, if required by the firm who get the Purchase Order for the period of 1 month.

13. Toggle Clamps 207U  
Quantity : 24 numbers

Note: 1. Sample of item will be issued on Returnable Gate Pass, if required by the firm who get the Purchase Order for the period of 1 month.

14. Toggle Clamps 201U  
Quantity : 24 numbers

Note: 1. Sample of item will be issued on Returnable Gate Pass, if required by the firm who get the Purchase Order for the period of 1 month.

15. Sprocket for Coin blank conveyor  
Quantity : 24 numbers  
Firm may visit IGMK and see the sample before submitting tender.

Note: 1. Sample of item will be issued on Returnable Gate Pass, if required by the firm who get the Purchase Order for the period of 1 month.

16. Collar Switch assy. for MRH-150  
Quantity : 15 numbers  
24 V power supply  
Firm may visit IGMK and see the sample before submitting tender.

Note: 1. Sample of item will be issued on Returnable Gate Pass, if required by the firm who get the Purchase Order for the period of 1 month.

17. Collar Switch assy. for MRV-150  
24 V power supply  
Quantity : 3 numbers  
Firm may visit IGMK and see the sample before submitting tender.

Note: 1. Sample of item will be issued on Returnable Gate Pass, if required by the firm who get the Purchase Order for the period of 1 month.

18. FOUNDATION SPRING-SCHULER PRESS  
Quantity : 200 Each Length 105mm,Coil Dia 8mm, Outer Dia 51mm, Inner Dia 35mm, No of Coils 6.5,  
Compressive Strength(Load) is over 5.29KN(539.4kg).  
Chemical Composition (% by mass- Carbon 0.045, Sulphur 0.01, Phosphorous 0.025, Silicon 1.42,  
Manganese 0.79

Note: 1. Sample of item will be issued on Returnable Gate Pass, if required by the firm who get the Purchase Order for the period of 1 month.

19. Reconditioning of indexing unit  
Quantity : 7 Nos.  
Scope of work:

Replacement of input and output shafts, 16 nos. of cam followers, synthetic gear oil, seals and bearings, and any other repairing required to put the indexing unit back in operation.

Note: 1. Sample of item will be issued on Returnable Gate Pass, if required by the firm who get the Purchase Order for the period of 1 month.

	Rs. 1/-	Rs. 2/-	Rs. 5/-	Rs. 10/-	Rs. 20/-
D1	19.75±0.05	22.63±0.04	24.75±0.05	26.58±0.04	26.00±0.05
s	1.5±0.05	1.5±0.05	1.84±0.05	1.82±0.05	2.08±0.05
t	6.25-0.05	6.25-0.05	5.91-0.05	5.93-0.05	5.67-0.05
b	18.75	21.63	23.75	25.58	25
a	19.75	22.63	24.75	26.58	26
c	21.38	18.5	16.38	14.55	15.13

EINZELHEIT X  
M 10:1

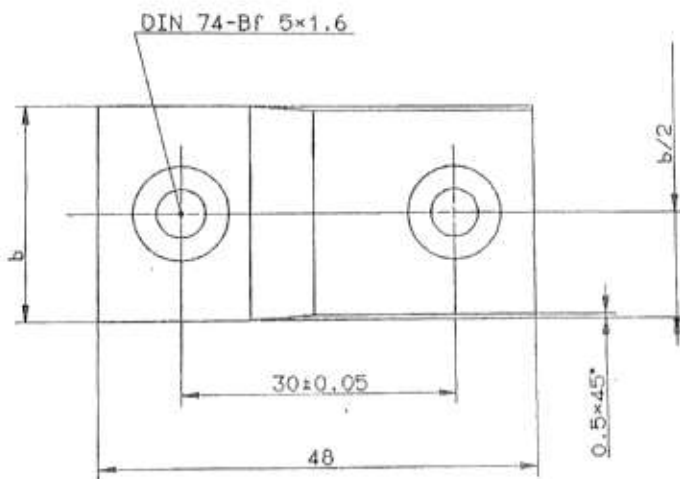
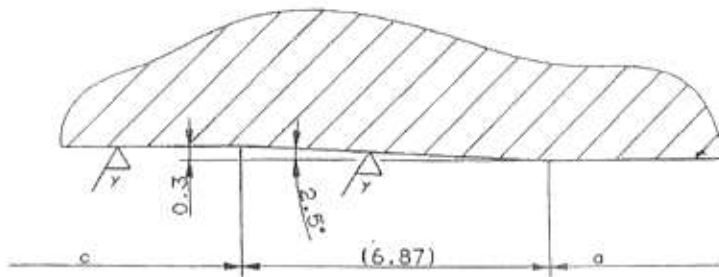

Material: D2  
Hardness: 59±2 HRC  
60±2 HRC

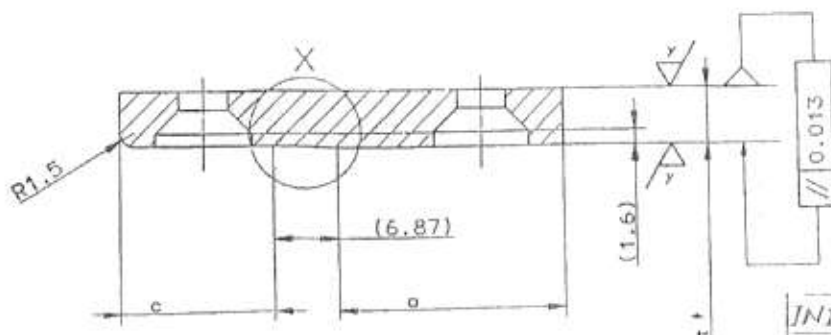

Thickness monitor  
MRH/MRV-150

INDIA GOVT. MINT. ALIPORE  
DATE - 05/07/2013 P.S.-NO. H/458

DRAWN

CHECKED

D.M. P. Tal  
05/07/2013  
M.T.O.

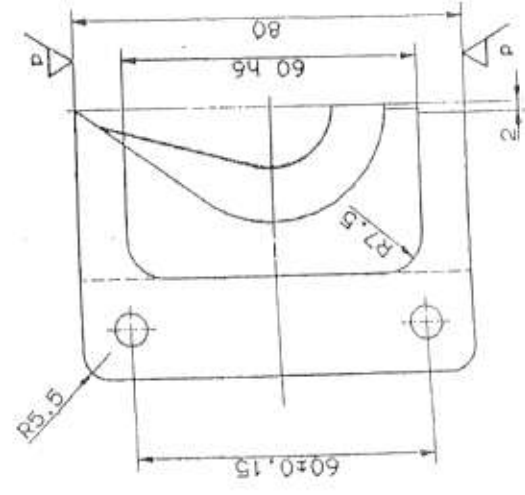
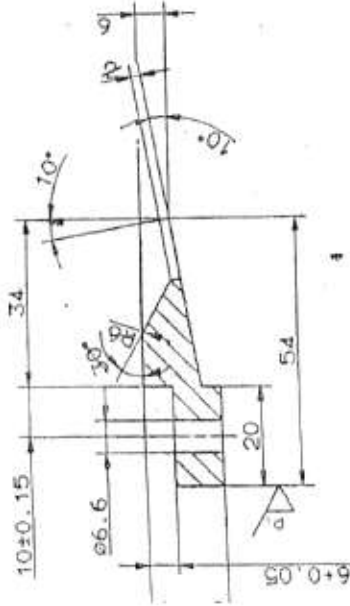

	Rs. 1/-	Rs. 2/-	Rs. 5/-	Rs. 10/-	Rs. 20/-
D1	19.75±0.05	22.63±0.04	24.75±0.05	26.58±0.04	26.00±0.05
d	20.25±0.2	23.13±0.2	25.25±0.2	27.08±0.2	26.5±0.2

Material: D2  
Hardness: 60±2 HRC

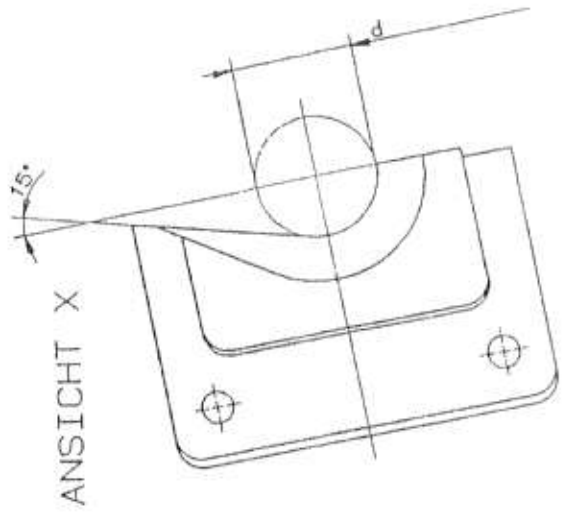

GUIDE PIECE  
MRV-150

INDIA GOVERNMENT MINT, KOL.	
DATE: 05.07.21	DRG. NO. H/459
<i>[Signature]</i> DRAWN	<i>[Signature]</i> I.M
<i>[Signature]</i> CHECKED	<i>[Signature]</i> M(EO)

	Rs. 1/-	Rs. 2/-	Rs. 5/-	Rs. 10/-	Rs. 20/-
D1	19.75±0.05	22.63±0.04	24.75±0.05	26.58±0.04	26.00±0.05
d	20.75±0.2	23.63±0.2	25.75±0.2	27.58±0.2	27.00±0.2
t	10.625	9.185	8.125	7.21	7.5

DIN 74-KM 4

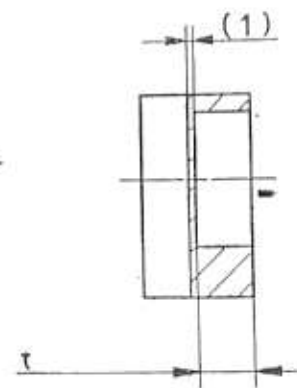
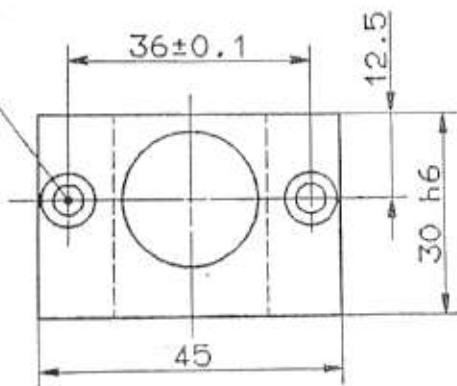

Material: Nylon

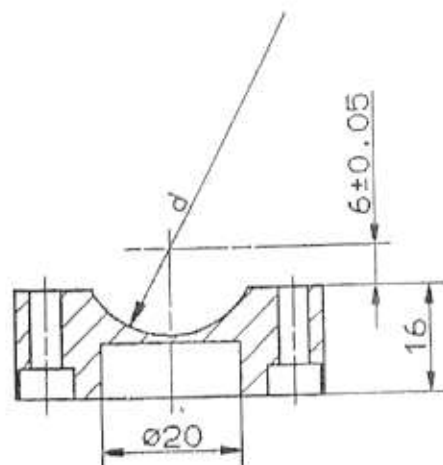

SIDE SUPPORT  
MRV-150

INDIA GOVT. ...	...
TITLE ...	... H/460
DRAWN BY <i>[Signature]</i>	<i>[Signature]</i> D.M. Setai
CHECKED BY <i>[Signature]</i>	<i>[Signature]</i> P.M. (T.O.)

	Rs. 1/-	Rs. 2/-	Rs. 5/-	Rs. 10/-	Rs. 20/-
D1	19.75±0.05	22.63±0.04	24.75±0.05	26.58±0.04	26.00±0.05
d	20.75+0.2	23.63+0.2	25.75+0.2	27.58+0.2	27.00+0.2
b	10.375	11.815	12.875	13.79	13.5

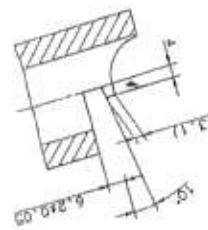
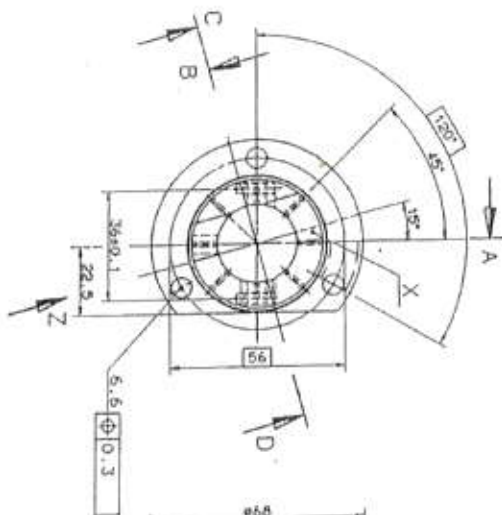
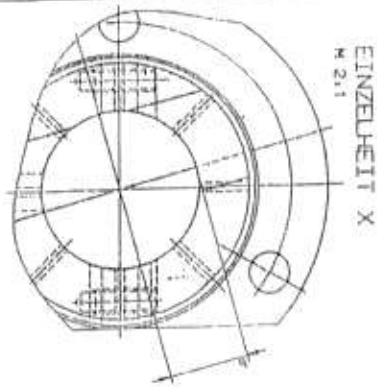

Section C-D

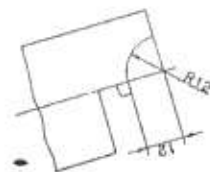

Z- Axis view

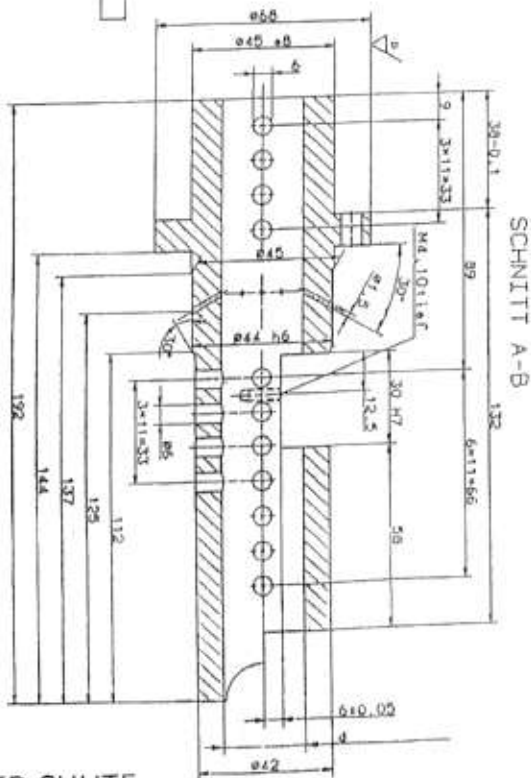

FEED CHUTE  
MRV-150

Material: D2  
Hardness: 60±2 HRC

INDIA GOVT. MINT. ALIPHJE, KUL	
DATE: 05.07.21	DRC. NO. H/461
DRAWN <i>[Signature]</i>	<i>[Signature]</i> D.M 5/7/21
CHECKED <i>[Signature]</i>	<i>[Signature]</i> M(T.O)



	Rs. 1/-	Rs. 2/-	Rs. 5/-	Rs. 10/-	Rs. 20/-
D1	19.75±0.05	22.63±0.04	24.75±0.05	26.58±0.04	26.00±0.05
s	1.5±0.05	1.5±0.05	1.84±0.05	1.82±0.05	2.08±0.05
d	20.25±0.1	23.13±0.1	25.25±0.1	27.08±0.1	26.5±0.1
h	2.0±0.1	2.0±0.1	2.34±0.1	2.32±0.1	2.58±0.1
h1	24.0±0.1	24.0±0.1	23.66±0.1	23.68±0.1	23.42±0.1
d1	21.25±0.2	24.13±0.2	26.25±0.2	28.08±0.2	27.5±0.2
a	20.75±0.2	23.63±0.2	25.75±0.2	27.58±0.2	27.00±0.2
h2	21.8±0.1	21.8±0.1	21.8±0.1	21.8±0.1	21.8±0.1

Material: D2  
Hardness: 60±2 HRC  
FEED CHUTE BASE PLATE  
MRV-150

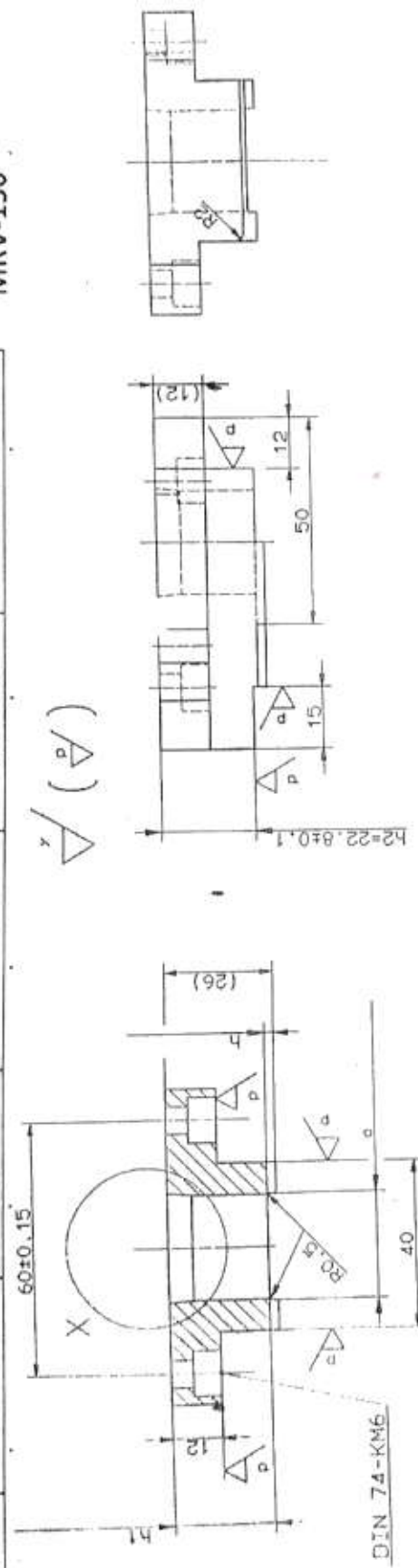

EINZELHEIT X  
M 2:1

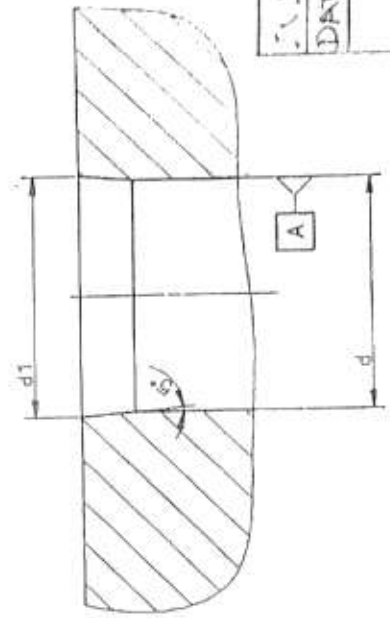
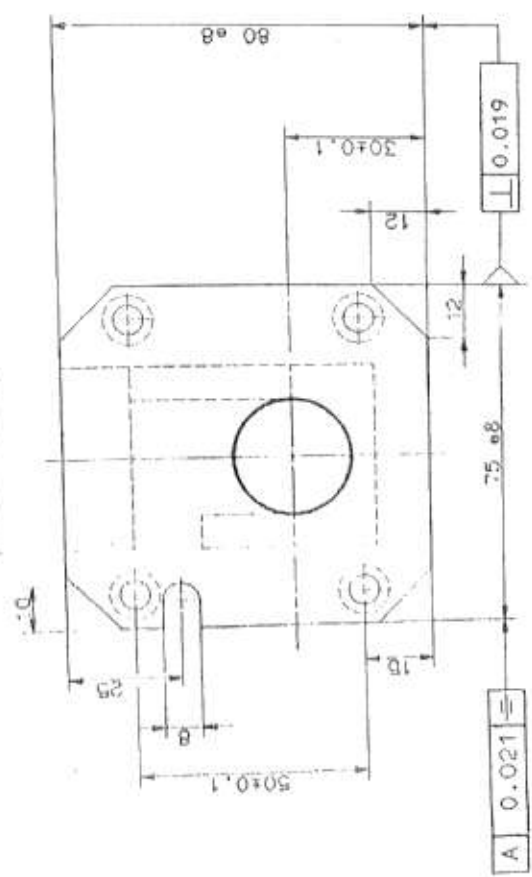

DATE: 15/07/21 DRG. NO. H/462  
DRAWN BY: [Signature]  
CHECKED BY: [Signature]

	Rs. 1/-	Rs. 2/-	Rs. 5/-	Rs. 10/-	Rs. 20/-
D1	19.75±0.05	22.63±0.04	24.75±0.05	26.58±0.04	26.00±0.05
a	1.5	3	3	3	3
b	19.75±0.05	22.63±0.04	24.75±0.05	26.58±0.04	26.00±0.05
c	70.625	67.685	66.625	65.71	66
h	1.3	1.3	1.64	1.62	1.88
s	1.5±0.05	1.5±0.05	1.84±0.05	1.82±0.05	2.08±0.05

D1

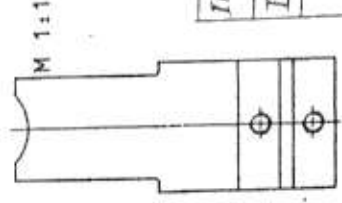
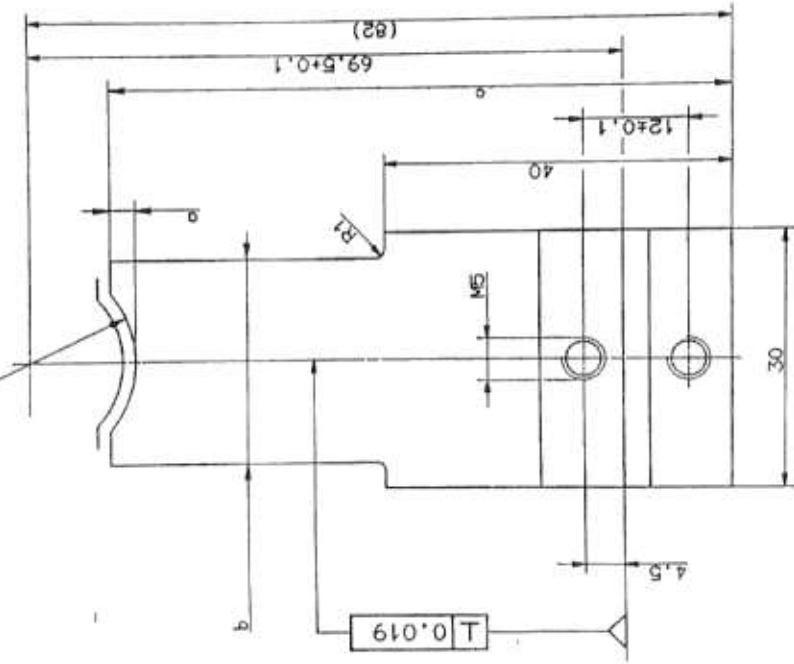
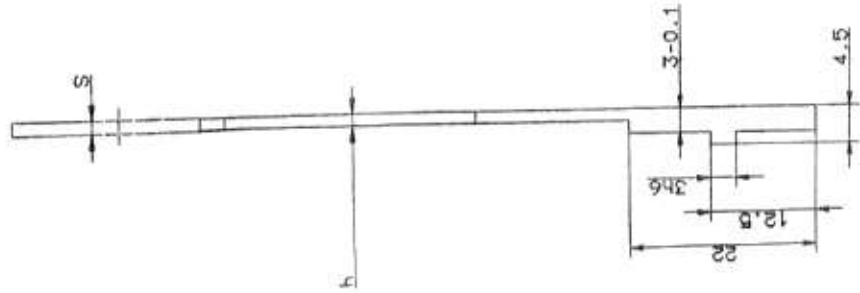

Material: D2  
 Hardness: 60±2 HRC  
 Pusher for MRV-150

INDIA GOVT. MINT, ALIPORE	DATE-05.07.21	DRG. NO. H/463
	DRAWN BY <i>[Signature]</i>	<i>[Signature]</i>
	CHECKED <i>[Signature]</i>	<i>[Signature]</i> (T.O)



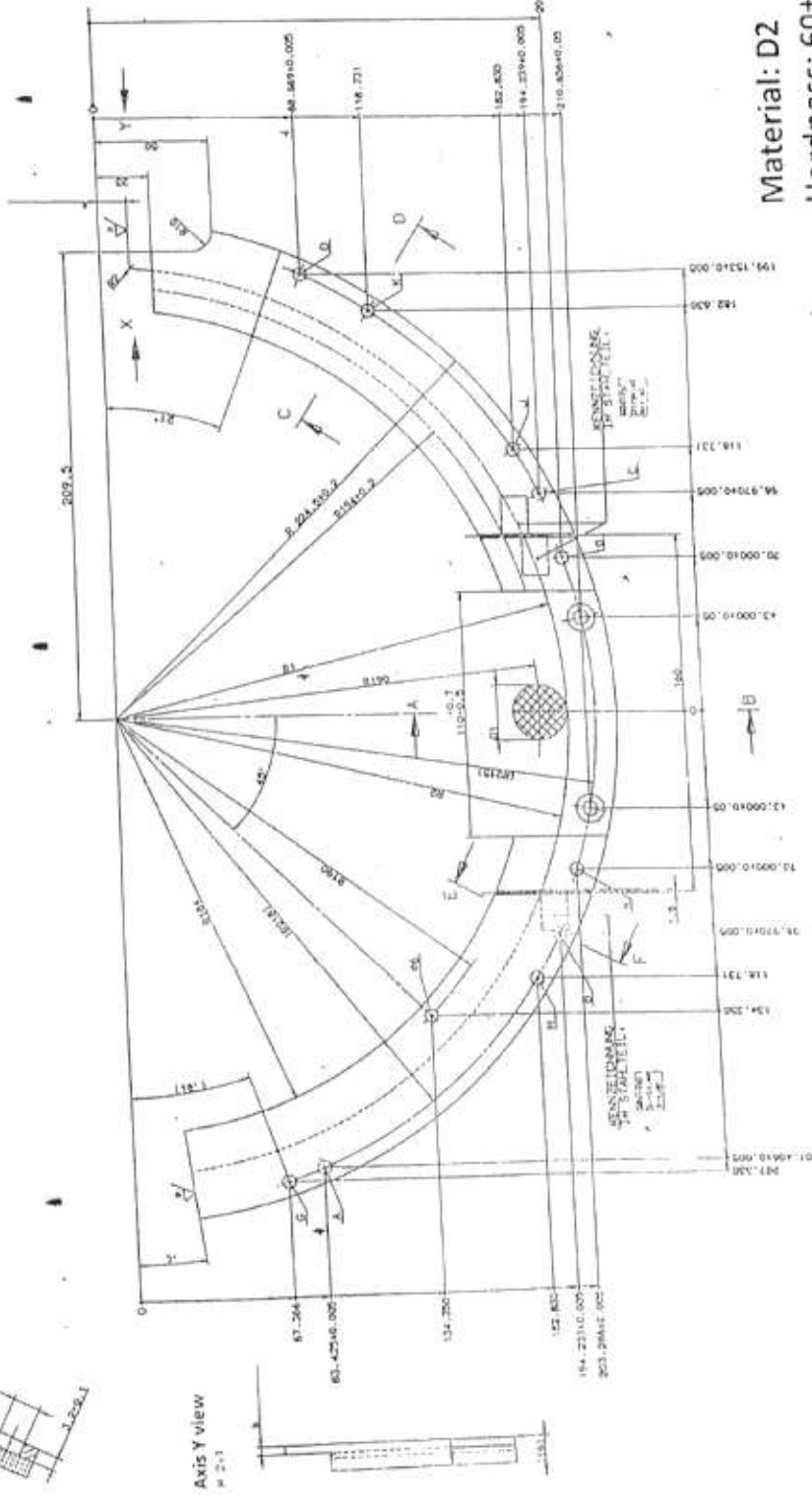
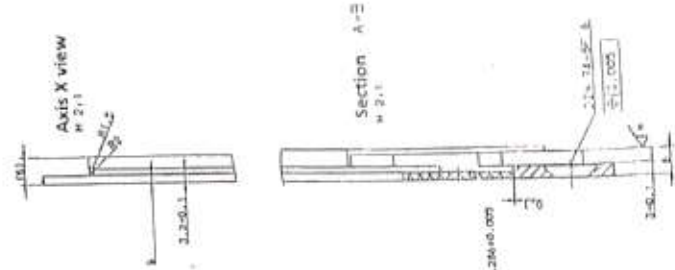
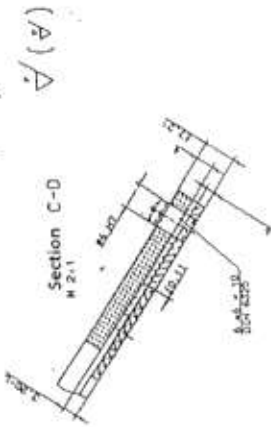

Material: D2  
Hardness: 60±2 HRC

SEGMENT FOR MRV COINING PRESS  
Denomination change parts(3 piece) of  
MRV-150

	Rs. 1/-	Rs. 2/-	Rs. 5/-	Rs. 10/-	Rs. 20/-
D1	19.75±0.05	22.63±0.04	24.75±0.05	26.58±0.04	26.00±0.05
S	1.5±0.05	1.5±0.05	1.8±0.05	1.82±0.05	2.08±0.05
R1	199.975±0.05	201.415±0.05	202.475±0.05	203.39±0.05	203.1±0.05
b	1.8±0.1	1.8±0.1	2.14±0.1	2.12±0.1	2.38±0.1
c	10.475±0.1	11.915±0.1	12.975±0.1	13.89±0.1	13.5±0.1
R2	200.475±0.1	201.915±0.1	202.975±0.1	203.89±0.1	203.6±0.1

INDIA GOVT. MINT, KOLKATA  
DATE-05.07.21 DRG.NO.-H/464

Checked: [Signature]  
I-RAN CHECKED I-M [Signature] (T.D)

	Rs. 1/-	Rs. 2/-	Rs. 5/-	Rs. 10/-	Rs. 20/-
D1	19.75±0.05	22.63±0.04	24.75±0.05	26.58±0.04	26.00±0.05
D2	20	23	25	27	27
a	14.925±0.1	13.485±0.1	12.425±0.1	11.51±0.1	11.8±0.1
b	13.025±0.1	11.585±0.1	10.525±0.1	9.61±0.1	9.9±0.1
Rc	200.2±0.05	201.7±0.05	202.7±0.05	203.7±0.05	203.7±0.05
K	4.8	3.3	2.3	1.3	1.3

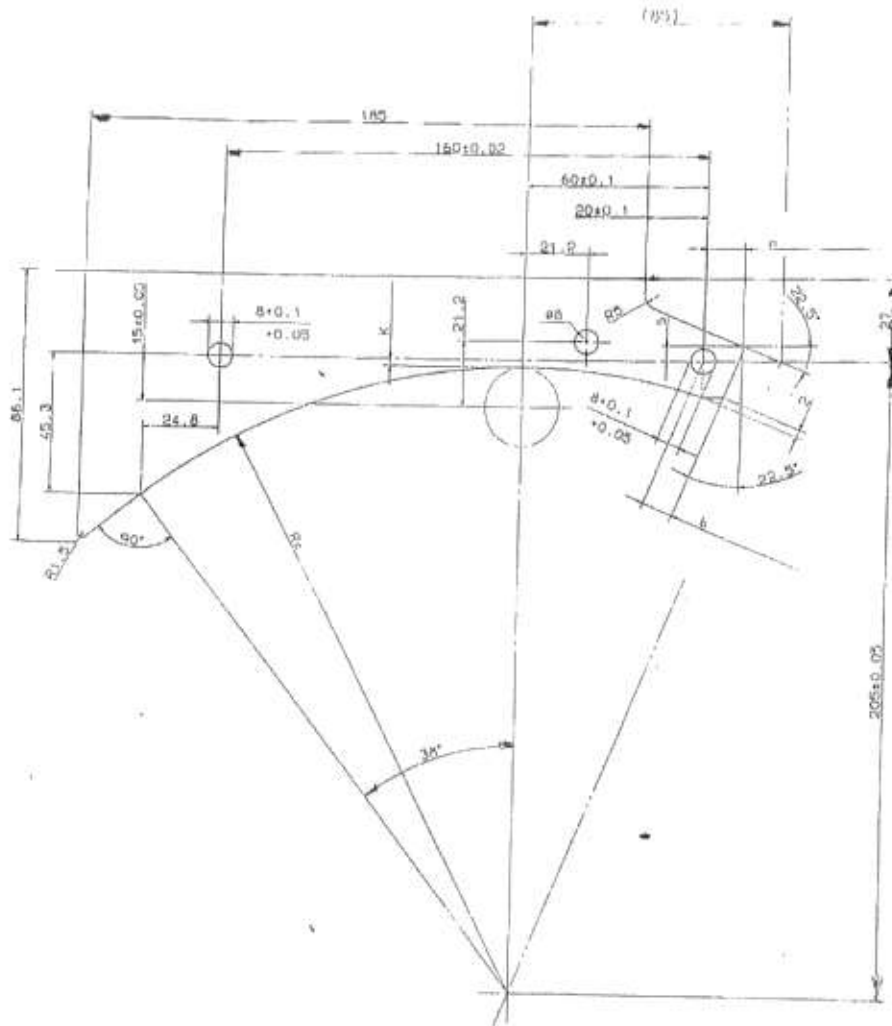

Material: D2  
Hardness: 60±2 HRc

COIN PLATE A FOR MRH-150

INDIA GOVT. MINT. KOLKATA  
DATE: 03/07/21 - IFC. NO. H/466

DRAWN BY <i>[Signature]</i>	<i>[Signature]</i> D.M.
CHECKED BY <i>[Signature]</i>	<i>[Signature]</i> D.M. (T.O)

	Rs. 1/-	Rs. 2/-	Rs. 5/-	Rs. 10/-	Rs. 20/-
D2	20	23	25	27	27
R	10	11.5	12.5	13.5	13.5

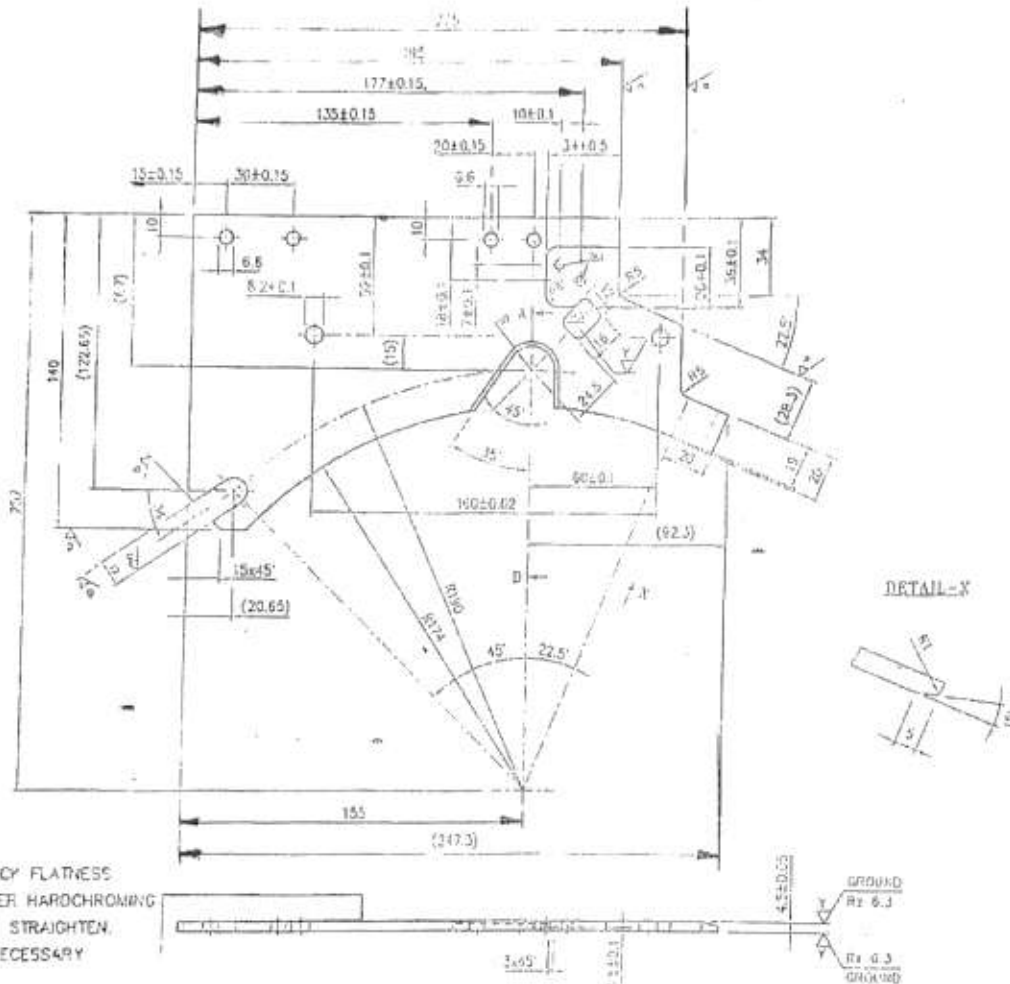

CHECK FLATNESS  
AFTER HARDCHROMING  
AND STRAIGHTEN  
IF NECESSARY

ENLARGED DETAIL-X



SECTION A-B  
SCALE 2:1

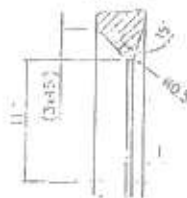

Material: D2

Hardness: 60±2 HRC

COIN PLATE B FOR MRH-150

INDIA GOVT. MINT-KOLKATA

DATE: 20-11-11 DRG. NO. H/467

DRAWN BY

CHECKED BY

*[Signature]*

*[Signature]*



496

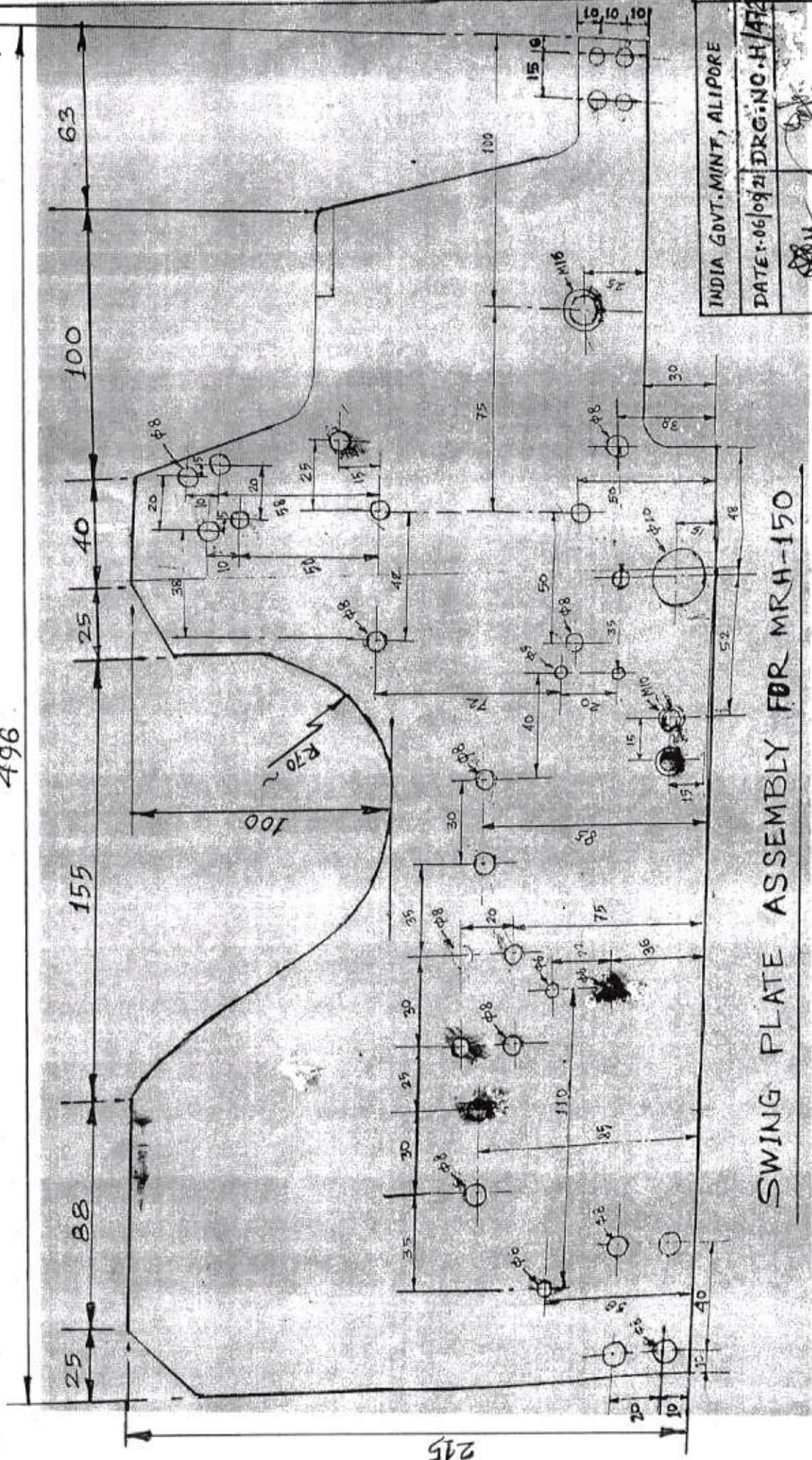

SWING PLATE ASSEMBLY FOR MRH-150

HARDNESS: - 180 VHN @ 30KG. Loading / 10 HRC

INDIA GOVT. MINT, ALIPORE	
DATE: 06/09/21	DRG. NO. H/472
<i>[Signature]</i>	M (T.O.)
DRAWN	<i>[Signature]</i>
CHECKED	D.G.M (T.O.)

Manufacturer’s Authorization Form

To  
India Government Mint, Kolkata  
A unit of Security Printing & Minting  
Corporation of India Limited  
(Wholly owned by Govt. of India)

Ref. Your Tender document No....., dated .....

Dear Sirs,

We, ....., who are proven and reputable  
manufacturers of ..... (*name and description of the goods  
offered in the tender*) having factories at....., hereby  
authorize Messrs..... (*name and address of the  
agent*) to submit a tender, process the same further and enter into a contract with you  
against your requirement as contained in the above referred tender enquiry documents for  
the above goods manufactured by us.

We further confirm that no supplier or firm or individual other than Messrs.  
..... (*name and address of the above agent*) is authorized to submit  
a tender, process the same further and enter into a contract with you against your  
requirement as contained in the above referred tender enquiry documents for the above  
goods manufactured by us.

We also hereby extend our full warranty, as applicable as per clause 16 of the General  
Conditions of Contract read with modification, if any, in the Special Conditions of  
Contract for the goods and services offered for supply by the above firm against this  
tender document.

Yours faithfully,

.....  
.....

[*Signature with date, name, and designation*]

for and on behalf of Messrs.....

[*Name & address of the manufacturers*]

*Note: This letter of authorization should be on the letter head of the manufacturing  
firm and should be signed by a person competent and having the power of attorney  
to legally bind the manufacturer.*