



Bid Number/बोली क्रमांक (बिड संख्या):
GEM/2023/B/3287833
Dated/दिनांक : 30-03-2023

Bid Document/ बिड दस्तावेज़

Bid Details/बिड विवरण	
Bid End Date/Time/बिड बंद होने की तारीख/समय	12-04-2023 15:00:00
Bid Opening Date/Time/बिड खुलने की तारीख/समय	12-04-2023 15:30:00
Bid Offer Validity (From End Date)/बिड पेशकश वैधता (बंद होने की तारीख से)	120 (Days)
Ministry/State Name/मंत्रालय/राज्य का नाम	Ministry Of Finance
Department Name/विभाग का नाम	Department Of Economic Affairs
Organisation Name/संगठन का नाम	Security Printing And Minting Corporation Of India Limited (spmci)
Office Name/कार्यालय का नाम	Janpath
Total Quantity/कुल मात्रा	30000
Item Category/मद केटेगरी	Conversion of rolled Cupro-Nickel (CN) strip into accessory, ' Fitting' of Medal (Q3)
Minimum Average Annual Turnover of the bidder (For 3 Years)/बिडर का न्यूनतम औसत वार्षिक टर्नओवर (3 वर्षों का)	37 Lakh (s)
Years of Past Experience Required for same/similar service/उन्हीं/समान सेवाओं के लिए अपेक्षित विगत अनुभव के वर्ष	1 Year (s)
MSE Exemption for Years Of Experience/वर्षों के अनुभव के लिए एमएसई को छूट प्राप्त है and Turnover/टर्नओवर के लिए एमएसई को छूट प्राप्त है	Yes
Startup Exemption for Years Of Experience/ वर्षों के अनुभव के लिए स्टार्टअप को छूट प्राप्त है and Turnover/ टर्नओवर के लिए स्टार्टअप को छूट प्राप्त है	Yes
Document required from seller/विक्रेता से मांगे गए दस्तावेज़	Experience Criteria,Past Performance,Bidder Turnover,Certificate (Requested in ATC),Additional Doc 1 (Requested in ATC),Additional Doc 2 (Requested in ATC),Compliance of BoQ specification and supporting document *In case any bidder is seeking exemption from Experience / Turnover Criteria, the supporting documents to prove his eligibility for exemption must be uploaded for evaluation by the buyer
Past Performance/विगत प्रदर्शन	40 %

Bid Details/बिड विवरण	
Bid to RA enabled/बिड से रिवर्स नीलामी सक्रिय किया	No
Type of Bid/बिड का प्रकार	Two Packet Bid
Time allowed for Technical Clarifications during technical evaluation/तकनीकी मूल्यांकन के दौरान तकनीकी स्पष्टीकरण हेतु अनुमत समय	7 Days
Evaluation Method/मूल्यांकन पद्धति	Total value wise evaluation

EMD Detail/ईएमडी विवरण

Advisory Bank/एडवाइजरी बैंक	Indusind bank
EMD Amount/ईएमडी राशि	185000

ePBG Detail/ईपीबीजी विवरण

Advisory Bank/एडवाइजरी बैंक	Indusind bank
ePBG Percentage(%) / ईपीबीजी प्रतिशत (%)	3.00
Duration of ePBG required (Months) / ईपीबीजी की अपेक्षित अवधि (महीने).	9

(a). EMD EXEMPTION: The bidder seeking EMD exemption, must submit the valid supporting document for the relevant category as per GeM GTC with the bid. Under MSE category, only manufacturers for goods and Service Providers for Services are eligible for exemption from EMD. Traders are excluded from the purview of this Policy./जेम की शर्तों के अनुसार ईएमडी छूट के इच्छुक बिडर को संबंधित केटेगरी के लिए बिड के साथ वैध समर्थित दस्तावेज प्रस्तुत करने हैं। एमएसई केटेगरी के अंतर्गत केवल वस्तुओं के लिए विनिर्माता तथा सेवाओं के लिए सेवा प्रदाता ईएमडी से छूट के पात्र हैं। व्यापारियों को इस नीति के दायरे से बाहर रखा गया है।

(b). EMD & Performance security should be in favour of Beneficiary, wherever it is applicable./ईएमडी और संपादन जमानत राशि, जहां यह लागू होती है, लाभार्थी के पक्ष में होनी चाहिए।

Beneficiary/लाभार्थी :

Materials Head
India Government Mint, Kolkata , West Bengal, Pin 700053
(Nayan Sarkar)

Splitting/विभाजन

Splitting Applied	Yes
Maximum No. Of Bidders Amongst Which Order May Be Split	3

MII Purchase Preference/एमआईआई खरीद वरीयता

MII Purchase Preference/एमआईआई खरीद वरीयता
--

Yes

MSE Purchase Preference/एमएसई खरीद वरीयता

MSE Purchase Preference/एमएसई खरीद वरीयता

Yes

1. If the bidder is a Micro or Small Enterprise as per latest definitions under MSME rules, the bidder shall be exempted from the requirement of "Bidder Turnover" criteria and "Experience Criteria" subject to meeting of quality and technical specifications. If the bidder is OEM of the offered products, it would be exempted from the "OEM Average Turnover" criteria also subject to meeting of quality and technical specifications. In case any bidder is seeking exemption from Turnover / Experience Criteria, the supporting documents to prove his eligibility for exemption must be uploaded for evaluation by the buyer.
2. If the bidder is a Startup, the bidder shall be exempted from the requirement of "Bidder Turnover" criteria and "Experience Criteria" subject to their meeting of quality and technical specifications. If the bidder is OEM of the offered products, it would be exempted from the "OEM Average Turnover" criteria also subject to meeting of quality and technical specifications. In case any bidder is seeking exemption from Turnover / Experience Criteria, the supporting documents to prove his eligibility for exemption must be uploaded for evaluation by the buyer.
3. The minimum average annual financial turnover of the bidder during the last three years, ending on 31st March of the previous financial year, should be as indicated above in the bid document. Documentary evidence in the form of certified Audited Balance Sheets of relevant periods or a certificate from the Chartered Accountant / Cost Accountant indicating the turnover details for the relevant period shall be uploaded with the bid. In case the date of constitution / incorporation of the bidder is less than 3-year-old, the average turnover in respect of the completed financial years after the date of constitution shall be taken into account for this criteria.
4. Experience Criteria: In respect of the filter applied for experience criteria, the Bidder or its OEM {themselves or through reseller(s)} should have regularly, manufactured and supplied same or similar Category Products to any Central / State Govt Organization / PSU / Public Listed Company for number of Financial years as indicated above in the bid document before the bid opening date. Copies of relevant contracts to be submitted along with bid in support of having supplied some quantity during each of the Financial year. In case of bunch bids, the category of primary product having highest value should meet this criterion.
5. Preference to Make In India products (For bids < 200 Crore): Preference shall be given to Class 1 local supplier as defined in public procurement (Preference to Make in India), Order 2017 as amended from time to time and its subsequent Orders/Notifications issued by concerned Nodal Ministry for specific Goods/Products. The minimum local content to qualify as a Class 1 local supplier is denoted in the bid document. If the bidder wants to avail the Purchase preference, the bidder must upload a certificate from the OEM regarding the percentage of the local content and the details of locations at which the local value addition is made along with their bid, failing which no purchase preference shall be granted. In case the bid value is more than Rs 10 Crore, the declaration relating to percentage of local content shall be certified by the statutory auditor or cost auditor, if the OEM is a company and by a practicing cost accountant or a chartered accountant for OEMs other than companies as per the Public Procurement (preference to Make-in -India) order 2017 dated 04.06.2020. Only Class-I and Class-II Local suppliers as per MII order dated 4.6.2020 will be eligible to bid. Non - Local suppliers as per MII order dated 04.06.2020 are not eligible to participate. However, eligible micro and small enterprises will be allowed to participate .In case Buyer has selected Purchase preference to Micro and Small Enterprises clause in the bid, the same will get precedence over this clause.
6. Purchase preference to Micro and Small Enterprises (MSEs): Purchase preference will be given to MSEs as defined in Public Procurement Policy for Micro and Small Enterprises (MSEs) Order, 2012 dated 23.03.2012 issued by Ministry of Micro, Small and Medium Enterprises and its subsequent Orders/Notifications issued by concerned Ministry. If the bidder wants to avail the Purchase preference, the bidder must be the manufacturer of the offered product in case of bid for supply of goods. Traders are excluded from the purview of Public Procurement Policy for Micro and Small Enterprises. In respect of bid for Services, the bidder must be the Service provider of the offered Service. Relevant documentary evidence in this regard shall be uploaded along with the bid in respect of the offered product or service. If L-1 is not an MSE and MSE Seller (s) has/have quoted price within L-1+ 15% (Selected by Buyer) of margin of purchase preference /price band defined in relevant policy, such Seller shall be given opportunity to match L-1 price and contract will be awarded for 25%(selected by Buyer) percentage of total QUANTITY.
7. Estimated Bid Value indicated above is being declared solely for the purpose of guidance on EMD amount and for determining the Eligibility Criteria related to Turn Over, Past Performance and Project / Past Experience etc. This has no relevance or bearing on the price to be quoted by the bidders and is also not going to have any impact on bid participation. Also this is not going to be used as a criteria in determining reasonableness of

quoted prices which would be determined by the buyer based on its own assessment of reasonableness and based on competitive prices received in Bid / RA process.

8. Past Performance: The Bidder or its OEM {themselves or through re-seller(s)} should have supplied same or similar Category Products for 40% of bid quantity, in at least one of the last three Financial years before the bid opening date to any Central / State Govt Organization / PSU / Public Listed Company. Copies of relevant contracts (proving supply of cumulative order quantity in any one financial year) to be submitted along with bid in support of quantity supplied in the relevant Financial year. In case of bunch bids, the category related to primary product having highest bid value should meet this criterion.

Conversion Of Rolled Cupro-Nickel (CN) Strip Into Accessory, ' Fitting' Of Medal (30000 pieces)

(Minimum 50% and 20% Local Content required for qualifying as Class 1 and Class 2 Local Supplier respectively/क्रमशः श्रेणी 1 और श्रेणी 2 के स्थानीय आपूर्तिकर्ता के रूप में अर्हता प्राप्त करने के लिए आवश्यक)

Brand Type/ब्रांड का प्रकार	Unbranded
-----------------------------	-----------

Technical Specifications/तकनीकी विशिष्टियाँ

Buyer Specification Document/क्रेता विशिष्टि दस्तावेज़	Download
--	--------------------------

Consignees/Reporting Officer/परेषिती/रिपोर्टिंग अधिकारी and/ तथा Quantity/मात्रा

S.No./क्र. सं.	Consignee Reporting/Officer/ परेषिती/रिपोर्टिंग अधिकारी	Address/पता	Quantity/मात्रा	Delivery Days/डिलीवरी के दिन
1	Indranil Payra	700053,India Govt Mint, Alipore Kolkata , West Bengal	30000	210

Buyer Added Bid Specific Terms and Conditions/क्रेता द्वारा जोड़ी गई बिड की विशेष शर्तें

1. Generic

OPTION CLAUSE: The Purchaser reserves the right to increase or decrease the quantity to be ordered up to 25 percent of bid quantity at the time of placement of contract. The purchaser also reserves the right to increase the ordered quantity by up to 25% of the contracted quantity during the currency of the contract at the contracted rates. Bidders are bound to accept the orders accordingly.

2. Generic

Bidder financial standing: The bidder should not be under liquidation, court receivership or similar proceedings, should not be bankrupt. Bidder to upload undertaking to this effect with bid.

3. Generic

Bidders are advised to check applicable GST on their own before quoting. Buyer will not take any

responsibility in this regards. GST reimbursement will be as per actuals or as per applicable rates (whichever is lower), subject to the maximum of quoted GST %.

4. **Generic**

While generating invoice in GeM portal, the seller must upload scanned copy of GST invoice and the screenshot of GST portal confirming payment of GST.

5. **Forms of EMD and PBG**

Bidders can also submit the EMD with Account Payee Demand Draft in favour of

India Government Mint, Kolkata (A unit of SPMCIL)
payable at
Kolkata

. Bidder has to upload scanned copy / proof of the DD along with bid and has to ensure delivery of hardcopy to the Buyer within 5 days of Bid End date / Bid Opening date.

6. **Forms of EMD and PBG**

Bidders can also submit the EMD with Fixed Deposit Receipt made out or pledged in the name of A/C (Name of the Buyer). The bank should certify on it that the deposit can be withdrawn only on the demand or with the sanction of the pledgee. For release of EMD, the FDR will be released in the favour of the bidder by the Buyer after making endorsement on the back of the FDR duly signed and stamped along with covering letter. Bidder has to upload scanned copy/ proof of the FDR along with bid and has to ensure delivery of hardcopy to the Buyer within 5 days of Bid End date/ Bid Opening date

7. **Forms of EMD and PBG**

Bidders can also submit the EMD with Banker's Cheque in favour of

India Government Mint, Kolkata (A unit of SPMCIL)
payable at
Kolkata

. Bidder has to upload scanned copy / proof of the BC along with bid and has to ensure delivery of hardcopy to the Buyer within 5 days of Bid End date / Bid Opening date.

8. **Forms of EMD and PBG**

Successful Bidder can submit the Performance Security in the form of Account Payee Demand Draft also (besides PBG which is allowed as per GeM GTC). DD should be made in favour of

India Government Mint, Kolkata (A unit of SPMCIL)
payable at
Kolkata

. After award of contract, Successful Bidder can upload scanned copy of the DD in place of PBG and has to ensure delivery of hard copy to the original DD to the Buyer within 15 days of award of contract.

9. **Forms of EMD and PBG**

Successful Bidder can submit the Performance Security in the form of Fixed Deposit Receipt also (besides PBG which is allowed as per GeM GTC). FDR should be made out or pledged in the name of

India Government Mint, Kolkata (A unit of SPMCIL)
A/C (Name of the Seller). The bank should certify on it that the deposit can be withdrawn only on the demand or with the sanction of the pledgee. For release of Security Deposit, the FDR will be released in favour of bidder by the Buyer after making endorsement on the back of the FDR duly signed and stamped along with covering letter. Successful Bidder has to upload scanned copy of the FDR document in place of PBG and has to ensure delivery of hard copy of Original FDR to the Buyer within 15 days of award of contract.

10. **Buyer Added Bid Specific ATC**

Buyer Added text based ATC clauses

1. Eligible Goods and Services (Origin of Goods):

(i) All goods and services to be supplied and provided for the contract shall have the origin in India or in the countries with which the Government of India has trade relations. (ii) The word "origin" incorporated in this clause means the place from where the goods are mines, cultivated, grown, manufactured, produced or processed or from where the service are arranged.

2. Special Condition: Supplier should file the returns pertaining to TCS (Section 206C (1H) for TCS collected, in the time and provide the TCS certificate to IGMK. In case of any Credit loss to IGMK by way of their failure to file Returns and provide TCS certificate in time, India Government Mint, Kolkata reserves the right to recover the amount equivalent to TCS paid along with applicable interest from the payment of further supplies.

3. GST Return:

Supplier should file the GST return for outward supplies in time. In case of any loss to India Government Mint, Kolkata by way of their failure to file GST Returns in time India Government Mint, Kolkata reserves the right to withhold the payment of further supplies till production of evidence. Any liability which will occurred on account of non-compliance of e-way bill, GST provision or any other applicable law will be borne by the supplier.

4. Consignee:

Chief General Manager, India Government Mint, Alipore, Kolkata

On the consignment please mention the following details:

Order No : Packing No : Net Weight : Gross Weight :

5. Packing:

Items should be suitably packed. The packing should be weather proof and should be made water proof to prevent damage during transit. The supplier will also be responsible for unloading and stacking at Mint Store as per instruction of competent authority.

6. Delivery Period:

The firm should supply the first lot of minimum 3000 pieces of the finished product i.e. Cupro-Nickel (CN) Fitting within 30 days from the date of issue of Contract. In the event of parallel contract, quantity will be distributed proportionately.

In the event of failure of the firm to meet the qualitative requirement of the CN Fitting to be supplied at the time of supply of the first lot; India Government Mint, Kolkata reserves the right to terminate the contract without citing any further reasons.

After successful supply of the above said first lot by the firm, they should supply at the rate of minimum 4500 pieces of Cupro-Nickel (CN) Fitting per month. In the event of parallel contract, quantity will be distributed proportionately.

Overall delivery period will be 7 (Seven) months from the date of issue of contract and the successful bidders must deliver good quality CN Fitting in full quantity within the stipulated overall delivery date; failing which liquidated damage (LD) charges will be imposed as per standard terms and conditions of tender enquiry.

7. Terms and Mode of payments:

100% payment on receipt as per delivery schedule and acceptance of goods & services by the user section and on production of all required documents by the supplier.

8. Transportation of Domestic Goods:

To be borne by the supplier.

9. Insurance:

The supplier shall make arrangements for insuring the goods against loss or damage, incidental to manufa

cture or acquisition, transportation, storage and delivery. The insurance cover shall be obtained by the supplier in its own name not in the name of India Government Mint, Kolkata or its consignee.

10. Quantum of LD:

If the supplier fails to deliver any or all of the goods or fails to perform the services within the time frame(s) incorporated in the contract, India Govt. Mint, Kolkata shall, without prejudice to other rights and remedies available to India Govt. Mint, Kolkata under the contract, deduct from the contract price, as liquidated damages, a sum equivalent to the 0.5% of the delivered price of the delayed goods and/ or services for each week of delay or part thereof until actual delivery or performance, subject to a maximum deduction of the 10% of the delayed goods' or services' contract price(s).

11. Resolution of Disputes:

If dispute or difference of any kind shall arise between India Government Mint, Kolkata and the supplier in connection with or relating the contract, the parties shall make every effort to resolve the same amicably by mutual consultations. If the parties fail to resolve the same amicably the mutual consultations. If the parties fail to resolve their dispute or difference by such mutual consultation within 21 days of its occurrence, then, unless otherwise provided in the SCC, either India Government Mint, Kolkata or the supplier may seek recourse to settlement of disputes through arbitration act 33.2. Disputes arising out of any breach of contract pertaining to this tender shall be settled in the court of competent jurisdiction located within Kolkata only.

12. Risk Purchase Clause :

(a) If the supplier after submission of tender and due acceptance of the same, i.e. after notification of award of contract fails to abide by the terms and conditions of these tender documents, or fails to supply the deliverables as per delivery schedule given or at any time repudiates the contract, the purchaser shall have the right to:

(i) Invoke the Security-cum-Performance Guarantee if deposited by the supplier and procure stores from other agencies at the risk and consequence of the supplier. The cost difference between the alternative arrangement and supplier tendered value will be recovered from the supplier.

(b) Supplier has to abide by all the terms and conditions of tender.

(c) In case of procurement through alternative sources and if procurement price is lower, no benefit on this account will be passed on to the supplier.

13. The total cost inclusive of all as cited above on FOR India Govt. Mint, Kolkata (W.B) basis should be indicated clearly both in words and figures in the price bid.

14. Documentary evidence to be submitted towards PAN & GST Registration Certificate.

15. Quality Control Requirements:

Quality of all service: Free from all technical defects, in compliance with our Technical Specification

i) Goods/service supplied not in conformity with tender specification will be treated as goods/service not supplied at all and supplier shall take supplied material not confirming to order specification back within 15 days. Goods/service shall be delivered by the supplier in accordance with the terms and conditions specified in the contract failing which expenses of keeping goods at purchaser's premises may be levied on supplier.

ii) Delivery date will be calculated from the date goods/services are received in acceptable quality in accordance with technical specification.

16. Parallel Contracts:

(i) Parallel contracts, with more than one bidder (for the same contract) may be concluded in the following cases:

(a) After due processing, if it is discovered that the quantity to be ordered is far more than what L-1 alone is capable of supplying (or has quoted for) and there was no prior stipulation in the bid document to split the quantities, then the quantity being finally ordered may be distributed among the other bidders by counter offering the L1 rate in a manner that is fair, transparent, and equitable. L-1 bidder must quote for minimum 60% of quantity.

(b) When it is decided in advance to have more than one source of supply due to the critical/ strategic/ specific nature of the supplies/ goods (and rate contracts are not appropriate for such goods) parallel contract clause should be added to the bid documents, clearly stating that India Government Mint, Kolkata reserves the right to split the contract quantity between suppliers. The manner of deciding relative share of lowest bidder (L1) contractor and the rest of the tenderers should be clearly defined, along with the minimum number of suppliers sought for the contract. In case of splitting it will be given to two vendors, in the ratio of 60:40, respectively. These ratios are approximate and India Government Mint, Kolkata reserves its right to marginally vary quantities to suit capacity of the firm/ unit loads of packing or transportation. However, the requirements may not be split into a number of tenders of smaller quantities for the reason that one supplier may not be able to supply the entire quantity. It should also be mentioned in such cases that the firms should not quote for less than 25% of the tendered quantity; otherwise, their offer would be considered as unresponsive.

(ii) Before splitting the quantity, it should be ensured that the L1 price is reasonable. If it is not reasonable, negotiation with the L1 party may be carried out with the approval of the CFA. The following guidelines are to be considered while opting for parallel contracts:

(a) L1 should be awarded at least the percentage mentioned above or his spare supply capacity, whichever is lower; and

(b) For the rest of the contract quantity, the lowest rate accepted will be counter offered to the L2 party. On acceptance of the counteroffer, the order will be placed on L2 for the respective percentage or the spare supply capacity of the L2 bidder, whichever is lower, and so on to other tenderers. In case of non-acceptance of the counteroffer by L2 party, a similar offer shall be made to L3 and L4 and so on.

(iii) For MSE firms, Parallel contract is applicable as per MSME guidelines issued time to time.

17. Purchaser reserves the right to reject all or any of the Bidders or Bids or to decide to drop the procurement process at any stage without assigning any reason.

18. MSME & Make in India Status:

In case any bidder is submitting their bid as MSME and/or MII, the firm must be registered as a MSME & MII in GeM portal and Self-declaration along with documentary evidence in this regard must be submitted declaring that their MSME & MII status is updated in GeM portal also. In further evaluation stage if it is found that the firm is not registered as MSME and/or MII in GeM, but MSME certificate and/or MII declaration is submitted along with the bid, no exemption will be given and their offer may be rejected.

19. Participating Bidder must submit sealed and signed copy of entire GeM bid document including the Scope of Work. Also the participating bidder must submit sealed, signed & duly filled copy of **Annexure I** attached under Technical Specification in their letter head.

20. The firm should not be blacklisted by any PSU or Government Authority and an undertaking must be given in the firm's letterhead in this regard.

21. All the supporting documents submitted along with this bid should be signed and sealed by the authorized signatory of the firm mandatorily.

22. Disclaimer :

The issue of this Bid Document does not imply that the Purchaser is bound to select Bidder(s) and the Purchaser reserves the right to reject all or any of the Bidders or Bids or to decide to drop the procurement process at any stage without assigning any reason.

23. Price Preference for MSE:

MSE quoting price within price band L1 + 15% may be awarded 25% of the total tendered value provided they agree to match the L1 price. In case of more than one such eligible MSE, 25% quantity is to be distributed proportionately among these bidders. Within this, a purchase preference of 4% is reserved for MSEs owned by SC/ ST entrepreneurs' and 3% is reserved for procurement from MSEs owned by women (if they participate in the tender process and match the L1 price, considering spirit of policy for enhancing the Govt. procurement from MSE).

24. Terms and Conditions:

Guidelines of SPMCIL Procurement Manual Version 2.0 will be applicable to this bid at any stage to avoid any conflict at later stage. Kindly refer GIT and GCC of SPMCIL Procurement Manual Version 2.0 for addition

al terms and conditions as per the links given below:

General Instruction to Tenderer (GIT): <https://spmCIL.com/uploaddocument/GIT/new.pdf>

General Conditions of Contract (GCC): <https://spmCIL.com/uploaddocument/GCC/new.pdf>

25 The supplier has to provide GeM invoice during submission of bill for payment.

26. Custody and return of Material loaned to contractor-

The successful firm must submit Bank Guarantee (BG) for an amount equivalent to the value of material of quantity minimum 3000 numbers of finished product. If more quantity of input material is taken for processing by the firm, BG of equivalent value to be submitted. As on date, the total value of BG for input material for equivalent quantity of 30,000 nos of finished product is Rs. 7,50,000.00 (approx.) The Firm have to issue Bank Guarantee with respect to the lifting quantity drawn in favour of India Government Mint, Kolkata (A unit of SPMCIL), payable at Kolkata, from any Scheduled Commercial Bank in acceptable form (i.e: Account Payee Demand Draft/Fixed Deposit Receipt/Bank Guarantee) valid till 60 days beyond the completion of delivery of finished product (CN Fitting). Final payment will be withheld if this is not done besides any other sanction deemed fit by Purchaser, i.e, India Government Mint, Kolkata. In the event of parallel contract, amount will be calculated proportionately.

27. Qualification/Eligibility Criteria:

A. EXPERIENCE & PAST PERFORMANCE : The bidder should have experience of having successfully completed similar kind of services for the value at least Rs.36,96,000/- in any one of the last five years ending on 31.03.2022.

Similar Kind of Services Means: Manufacturing products involving operations like cutting, slotting, drilling, soldering, wire drawing, polishing etc. for metals/ metal alloys.

IN SUPPORT OF EXPERIENCE & PAST PERFORMANCE COPY OF SUPPLY/ WORK ORDER; RESPECTIVE COMPLETION CERTIFICATE AND CONTACT DETAILS OF CLIENTS TO BE ENCLOSED ALONG WITH THE TENDER.

B. CAPABILITY - The bidder must have capability to provide the relevant services.

IN SUPPORT OF THE CAPABILITY THE BIDDER HAS TO SUBMIT COPY OF SUPPORTING DOCUMENTS i.e. DETAILS OF EQUIPMENT AND MANUFACTURING FACILITIES, ENGINEERS/MANAGERS DETAILS, NUMBER OF SKILLED LABORS AVAILABLE WITH THE FIRM, ETC.

NOTE: FOR VERIFYING THE CAPABILITY/CAPACITY, INDIA GOVT. MINT, KOLKATA RESERVES THE RIGHT TO DEPUTE ITS AUTHORISED REPRESENTATIVES AT THE WORKSITES. IN THE EVENT, THE FIRM IS FOUND NOT HAVING CAPABILITY/CAPACITY, THEIR OFFER IS LIABLE TO BE REJECTED.

C. FINANCIAL STANDING :

a) The average annual financial turnover of the bidder during the last three years, ending on 31.03.2022, should be at least Rs.36,96,000/- as per the annual report (audited balance sheet and profit & loss account) of the relevant period, duly authenticated by a Chartered Accountant/Cost Accountant in India.

b) The bidder should not have suffered any financial loss for more than one year during the last three years, ending on 31.03.2022.

c) i) The net worth of the Bidder should not be negative on 31.03.2022 and also

ii) should not have eroded by more than 30% in the last three years, ending on 31.03.2022.

SUPPORTING DOCUMENTS TO BE FURNISHED AS CLAIM AGAINST THE ABOVE ELIGIBILITY CRITERIA: ALL FINANCIAL STANDING DATA SHOULD BE CERTIFIED BY CERTIFIED ACCOUNTANTS e.g. CHARTERED ACCOUNTANTS (CA) IN INDIA.

NOTE:

1. BIDDER TO FURNISH STIPULATED DOCUMENTS IN SUPPORT OF FULFILLMENT OF ABOVE QUALIFYING CRITERIA i.e. EXPERIENCE & PAST PERFORMANCE, CAPABILITY AND FINANCIAL STANDING.

2. All copy of supply/ work order; respective completion certificate and contact details of clients: in support of experience, past performance and capacity/ capability should be authenticated by the by the person au

thorized to sign the tender on behalf of the bidder.

NON-SUBMISSION OR INCOMPLETE SUBMISSION OF DOCUMENTS MAY LEAD TO REJECTION OF OFFER.

28. Price to be mentioned only in price bid not in Techno commercial bid or any other place. If it is mentioned any other part other than price bid, the offer will be rejected.

Note:

All the copies of the tender shall be duly signed at the appropriate places as indicated in the bid documents and all other pages of the bid including printed literature, if any shall be initialled by the same person(s) signing the bid document. The bid document shall not contain any erasure or overwriting, except as necessary to correct any error made by the tenderer and, if there is any such correction; the same shall be initialled by the person(s) signing the tender.

***FOR ANY OTHER QUERIES, FIRMS MAY CONTACT IN THE BELOW DETAILS:**

Ph. No. 033 - 2401 4132,33,34,35, (Extension 336/ 319/ 326);

Email: purchase.igmk@spmcil.com

Disclaimer/अस्वीकरण

The additional terms and conditions have been incorporated by the Buyer after approval of the Competent Authority in Buyer Organization, whereby Buyer organization is solely responsible for the impact of these clauses on the bidding process, its outcome, and consequences thereof including any eccentricity / restriction arising in the bidding process due to these ATCs and due to modification of technical specifications and / or terms and conditions governing the bid. Any clause(s) incorporated by the Buyer regarding following shall be treated as null and void and would not be considered as part of bid:-

1. Definition of Class I and Class II suppliers in the bid not in line with the extant Order / Office Memorandum issued by DPIIT in this regard.
2. Seeking EMD submission from bidder(s), including via Additional Terms & Conditions, in contravention to exemption provided to such sellers under GeM GTC.
3. Publishing Custom / BOQ bids for items for which regular GeM categories are available without any Category item bunched with it.
4. Creating BoQ bid for single item.
5. Mentioning specific Brand or Make or Model or Manufacturer or Dealer name.
6. Mandating submission of documents in physical form as a pre-requisite to qualify bidders.
7. Floating / creation of work contracts as Custom Bids in Services.
8. Seeking sample with bid or approval of samples during bid evaluation process.
9. Mandating foreign / international certifications even in case of existence of Indian Standards without specifying equivalent Indian Certification / standards.
10. Seeking experience from specific organization / department / institute only or from foreign / export experience.
11. Creating bid for items from irrelevant categories.
12. Incorporating any clause against the MSME policy and Preference to Make in India Policy.
13. Reference of conditions published on any external site or reference to external documents/clauses.
14. Asking for any Tender fee / Bid Participation fee / Auction fee in case of Bids / Forward Auction, as the case may be.

Further, if any seller has any objection/grievance against these additional clauses or otherwise on any aspect of this bid, they can raise their representation against the same by using the Representation window provided in the bid details field in Seller dashboard after logging in as a seller within 4 days of bid publication on GeM. Buyer is duty bound to reply to all such representations and would not be allowed to open bids if he fails to reply to

such representations.

[This Bid is also governed by the General Terms and Conditions/ यह बिड सामान्य शर्तों के अंतर्गत भी शासित है](#)

In terms of GeM GTC clause 26 regarding Restrictions on procurement from a bidder of a country which shares a land border with India, any bidder from a country which shares a land border with India will be eligible to bid in this tender only if the bidder is registered with the Competent Authority. While participating in bid, Bidder has to undertake compliance of this and any false declaration and non-compliance of this would be a ground for immediate termination of the contract and further legal action in accordance with the laws./जेम की सामान्य शर्तों के खंड 26 के संदर्भ में भारत के साथ भूमि सीमा साझा करने वाले देश के बिडर से खरीद पर प्रतिबंध के संबंध में भारत के साथ भूमि सीमा साझा करने वाले देश का कोई भी बिडर इस निविदा में बिड देने के लिए तभी पात्र होगा जब वह बिड देने वाला सक्षम प्राधिकारी के पास पंजीकृत हो। बिड में भाग लेते समय बिडर को इसका अनुपालन करना होगा और कोई भी गलत घोषणा किए जाने व इसका अनुपालन न करने पर अनुबंध को तत्काल समाप्त करने और कानून के अनुसार आगे की कानूनी कार्रवाई का आधार होगा।

---Thank You/धन्यवाद---

Conversion of the rolled Cupro-Nickel (CN) strip into the accessory, 'Fitting' as per the sketch drawings (enclosed herewith), Qty. 30000 pcs, with the following scope of work.

A) Scope of supply on part of India Government Mint, Kolkata

1. Rolled Cupro-Nickel (CN) strip of (95 ± 5) mm width and (3 ± 0.2) mm thickness.

B) Scope of Work on Bidder's/Firm's part

1. The firm must supply the material strictly as per the sketch drawings and/or the reference sample available at India Government Mint, Kolkata. For reference purpose, representative(/s) of participating vendors may visit India Government Mint, Kolkata.

a) Rolled Cupro-Nickel (CN) strip of (95 ± 5) mm width and (3 ± 0.2) mm thickness will be provided by India Government Mint, Kolkata for manufacturing the CN Fitting

2. Carrying out all the necessary operations e.g., annealing, blanking, stamping, scissel cutting, drilling, wire drawing, soldering/brazing etc. on rolled CN strip of (95 ± 5) mm width and (3 ± 0.2) mm thickness to prepare the CN Fitting as per enclosed drawings. Approximate weight of each unit of CN Fitting shall weigh (5.0 ± 0.05) g.

3. Acid wash & Reetha wash of complete fitting to clean brazing marks.

4. Silver soldering of the finished fittings with the stamped medals at India Government Mint, Kolkata.

5. Acid wash of the complete assembly of medal along with the fitting at India Government Mint, Kolkata.

6. Hand-over of materials to India Government Mint, Kolkata.

Note to Bidders:

1. The firm may visit India Government Mint, Kolkata (with prior intimation) to see the material.
2. Sample of Fitting will be provided to the successful bidder firm by India Government Mint, Kolkata on returnable basis.
3. For each unit of Fitting, raw material as per following details will be provided:
Rolled Cupro-Nickel (CN) strip of (95 ± 5) mm width and (3 ± 0.2) mm thickness = 20.705 g (Considering 25% yield in manufacturing each Fitting with a process loss of maximum 2.5%)

Apart from the process loss part, the firm shall have to return all the excess CN materials (if any) along with the specified quantities of complete Fitting (30000 nos.).

#Custody and return of material loaned to contractor:

Raw Material will be provided by Purchaser i.e, India Government Mint, Kolkata. Whenever raw material is required to be issued to the firm/ contractor, these will be issued against appropriate Bank Guarantee. The firm must submit bank guarantee (BG) equivalent to the value of raw materials issued to them.

The bidder may kindly be asked to submit a BG to be kept valid till 60 days beyond the completion of Delivery of finished product (CN Fitting). The Bank Guarantee is to be furnished in favour of "India Government Mint, Kolkata (A Unit of SPMCIL), Payable at Kolkata. Final payment will be withheld if this is not done besides any other sanction deemed fit by Purchaser, i.e, India Government Mint, Kolkata.

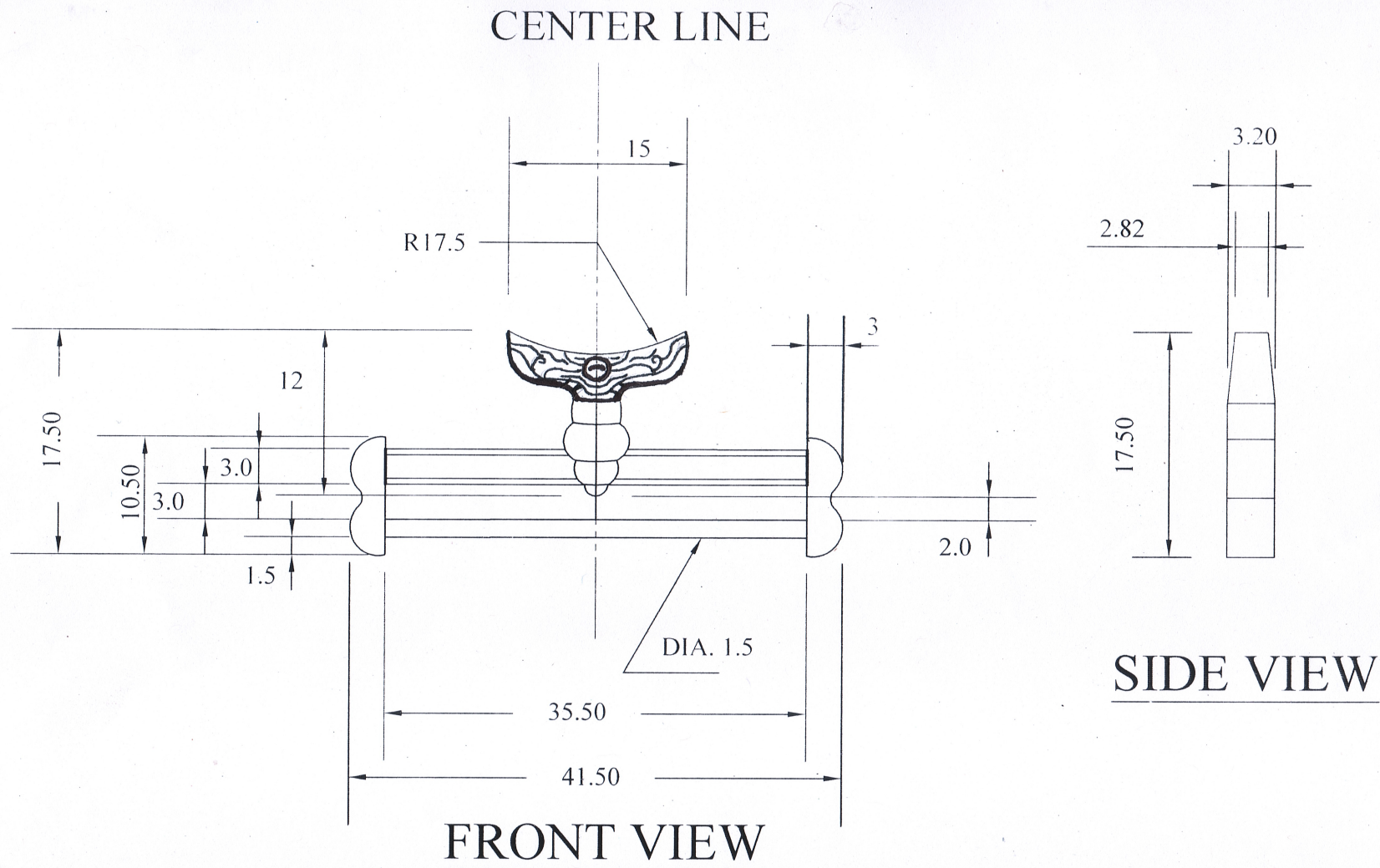

FITTING FOR
ANTRIK SURAKSHA SEVA MEDAL
(DIAMETER 35 MM)
WEIGHT : 5 GRAMS (+/- 0.05 GRAMS)

ALL DIMENSIONS ARE IN MM
 MEASUREMENTS ARE IN APPROX.

INDIA GOVERNMENT MINT
 KOLKATA

SKETCH DRAWING DATED 08-06-2022

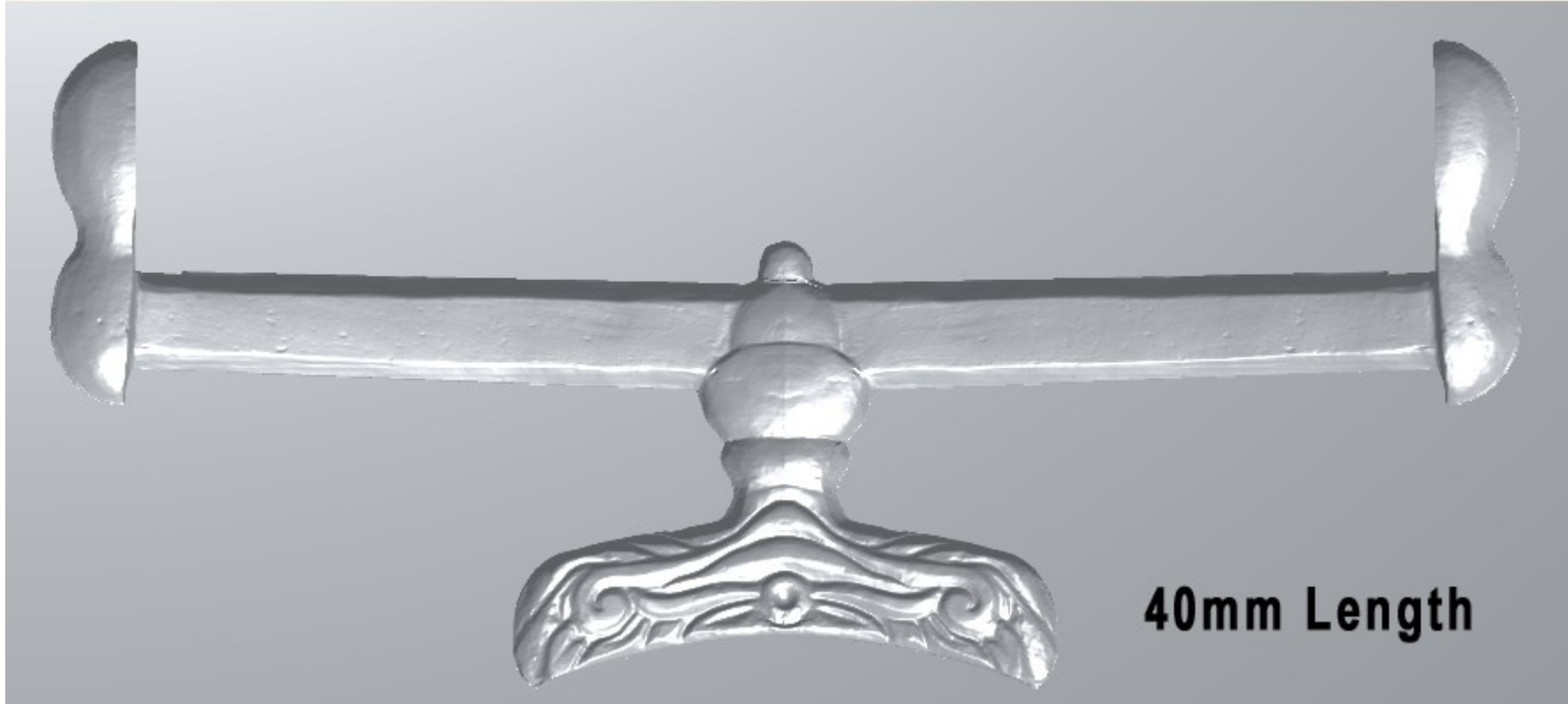

40mm Length

**GeM Bid Document No. :dated.
(To be submitted on the letter head of the bidder)**

DECLARATION

We do hereby declare that,

1. We have not been blacklisted/ debarred by BNPMIPL/BRBNMPL/SPMCIL or any Govt. Departments for participation in tenders. The information provided above is correct and true to the best of my knowledge and belief.
2. We do hereby declare that we have read and understood all terms and conditions of tender document including Technical Specification, buyer added additional terms & conditions, Quality Control Criteria and confirm to abide to those conditions without any counter conditions.
3. "We are accepting all the terms and conditions of the tender document unconditionally without any deviation"

Signature

Name

Designation

Date

Stamp of the Organization

CHECK LIST

Before Submission of Tender following points to be confirmed/complied by the participating bidder to avoid rejection of bid. Hence check every point & tick (✓) before final submission.

(iii) **Part I : (Techno Commercial Bid cover)**

Sl. No.	Tender Submission Check Points (To be complied by bidder before submission of Bid)	Check before submission Tick (✓)
1	Tender Document Duly Seal & Signed on every page including technical specification	
2	Term of Delivery : FOR, India Govt. Mint, Kolkata duly unloaded	
3	Tender Validity 120 days as per the tender	
4	Technical Specification – as per tender	
5	Submitted the documents as per Qualification / Eligibility criteria (iii) Proof of Experience : Purchase Order & Completion Certificate (ii) Proof of Capability : Details of plant and machinery (iii) Financial data : audited Balance sheets and Profit & Loss account statements of last three financial years	
6	Delivery Period : Acceptance of delivery period as per buyer added ATC	
7	Documentary evidence towards PAN & GST Registration Certificate	
8	Sealed & Signed Declaration (Annexure – I attached in technical specification)	
9	Proof of EMD(scanned copy) as applicable or any exemption certificate	
10	The firms participating as MSE/NSIC/DIC/Start-up India Campaign, needs to enclosed certificates containing validity	
11	Category of MSME Firms	
	SC	
	ST	
	GEN	
12	Owner of Company	
	Male	
	Female	
13	Documentary/undertaking against Make in India Status i.e. being a Class I/ Class II supplier with details of percentage	
14	All supporting documents submitted along with bid to be sealed and signed by Authorized signatory of the firm	

B. Part II : (Price Bid Cover)

Sl. No.	Description	Submitted/ Not Submitted
1	Price Bid (Price including all taxes & other charges), GST percentage to be mentioned mandatorily in the price bid, upload copy of the Price Details in Price Bid mentioning all the breakup of price	

- Price to be mentioned only in price bid not in Techno commercial bid or any other place. If it is mentioned any other part other than price bid, the offer will be rejected.