



Bid Number/बोली क्रमांक (बिड संख्या):
GEM/2024/B/5279564
Dated/दिनांक : 27-08-2024

Bid Document/ बिड दस्तावेज़

Bid Details/बिड विवरण	
Bid End Date/Time/बिड बंद होने की तारीख/समय	07-09-2024 15:00:00
Bid Opening Date/Time/बिड खुलने की तारीख/समय	07-09-2024 15:30:00
Bid Offer Validity (From End Date)/बिड पेशकश वैधता (बंद होने की तारीख से)	120 (Days)
Ministry/State Name/मंत्रालय/राज्य का नाम	Ministry Of Finance
Department Name/विभाग का नाम	Department Of Economic Affairs
Organisation Name/संगठन का नाम	Security Printing And Minting Corporation Of India Limited (spmci)
Office Name/कार्यालय का नाम	Janpath
Total Quantity/कुल मात्रा	100000
Item Category/मद केटेगरी	Conversion of the rolled Cupro-Nickel (CN) strips into the accessory, ' Brooch'
MSE Exemption for Years Of Experience/अनुभव के वर्षों से एमएसई छूट/ and Turnover/टर्नओवर के लिए एमएसई को छूट प्राप्त है	Yes
Startup Exemption for Years Of Experience/अनुभव के वर्षों से स्टार्टअप छूट/ and Turnover/ टर्नओवर के लिए स्टार्टअप को छूट प्राप्त है	Yes
Document required from seller/विक्रेता से मांगे गए दस्तावेज़	Certificate (Requested in ATC),Additional Doc 1 (Requested in ATC),Additional Doc 2 (Requested in ATC),Additional Doc 3 (Requested in ATC),Additional Doc 4 (Requested in ATC) *In case any bidder is seeking exemption from Experience / Turnover Criteria, the supporting documents to prove his eligibility for exemption must be uploaded for evaluation by the buyer
Bid to RA enabled/बिड से रिवर्स नीलामी सक्रिय किया	No
Type of Bid/बिड का प्रकार	Two Packet Bid
Time allowed for Technical Clarifications during technical evaluation/तकनीकी मूल्यांकन के दौरान तकनीकी स्पष्टीकरण हेतु अनुमत समय	3 Days
Inspection Required (By Empanelled Inspection Authority / Agencies pre-registered with GeM)	No

Bid Details/बिड विवरण

Evaluation Method/मूल्यांकन पद्धति	Total value wise evaluation
Financial Document Required/वित्तीय दस्तावेज की आवश्यकता है।	Yes

EMD Detail/ईएमडी विवरण

Advisory Bank/एडवाइजरी बैंक	State Bank of India
EMD Amount/ईएमडी राशि	191000

ePBG Detail/ईपीबीजी विवरण

Advisory Bank/एडवाइजरी बैंक	State Bank of India
ePBG Percentage(%) /ईपीबीजी प्रतिशत (%)	5.00
Duration of ePBG required (Months)/ईपीबीजी की अपेक्षित अवधि (महीने).	26

(a). EMD EXEMPTION: The bidder seeking EMD exemption, must submit the valid supporting document for the relevant category as per GeM GTC with the bid. Under MSE category, only manufacturers for goods and Service Providers for Services are eligible for exemption from EMD. Traders are excluded from the purview of this Policy./जेम की शर्तों के अनुसार ईएमडी छूट के इच्छुक बिडर को संबंधित केटेगरी के लिए बिड के साथ वैध समर्थित दस्तावेज प्रस्तुत करने हैं। एमएसई केटेगरी के अंतर्गत केवल वस्तुओं के लिए विनिर्माता तथा सेवाओं के लिए सेवा प्रदाता ईएमडी से छूट के पात्र हैं। व्यापारियों को इस नीति के दायरे से बाहर रखा गया है।

(b). EMD & Performance security should be in favour of Beneficiary, wherever it is applicable./ईएमडी और संपादन जमानत राशि, जहां यह लागू होती है, लाभार्थी के पक्ष में होनी चाहिए।

Beneficiary/लाभार्थी :

S P M Corporation of India Limited
Payable at Kolkata
(S P M Corporation Of India Limited)

Splitting/विभाजन

Splitting Applied	Yes
Maximum No. Of Bidders Amongst Which Order May Be Split	2
Split Criteria based on which quantity will be distributed	As per bid document

MII Purchase Preference/एमआईआई खरीद वरीयता

MII Purchase Preference/एमआईआई खरीद वरीयता	Yes
--	-----

MSE Purchase Preference/एमएसई खरीद वरीयता

MSE Purchase Preference/एमएसई खरीद वरीयता	Yes
---	-----

1. If the bidder is a Micro or Small Enterprise as per latest definitions under MSME rules, the bidder shall be exempted from the requirement of "Bidder Turnover" criteria and "Experience Criteria" subject to meeting of quality and technical specifications. If the bidder is OEM of the offered products, it would be exempted from the "OEM Average Turnover" criteria also subject to meeting of quality and technical specifications. In case any bidder is seeking exemption from Turnover / Experience Criteria, the supporting documents to prove his eligibility for exemption must be uploaded for evaluation by the buyer.

2. If the bidder is a Startup, the bidder shall be exempted from the requirement of "Bidder Turnover" criteria and "Experience Criteria" subject to their meeting of quality and technical specifications. If the bidder is OEM of the offered products, it would be exempted from the "OEM Average Turnover" criteria also subject to meeting of quality and technical specifications. In case any bidder is seeking exemption from Turnover / Experience Criteria, the supporting documents to prove his eligibility for exemption must be uploaded for evaluation by the buyer.

3. Preference to Make In India products (For bids < 200 Crore): Preference shall be given to Class 1 local supplier as defined in public procurement (Preference to Make in India), Order 2017 as amended from time to time and its subsequent Orders/Notifications issued by concerned Nodal Ministry for specific Goods/Products. The minimum local content to qualify as a Class 1 local supplier is denoted in the bid document. If the bidder wants to avail the Purchase preference, the bidder must upload a certificate from the OEM regarding the percentage of the local content and the details of locations at which the local value addition is made along with their bid, failing which no purchase preference shall be granted. In case the bid value is more than Rs 10 Crore, the declaration relating to percentage of local content shall be certified by the statutory auditor or cost auditor, if the OEM is a company and by a practicing cost accountant or a chartered accountant for OEMs other than companies as per the Public Procurement (preference to Make-in -India) order 2017 dated 04.06.2020. Only Class-I and Class-II Local suppliers as per MII order dated 4.6.2020 will be eligible to bid. Non - Local suppliers as per MII order dated 04.06.2020 are not eligible to participate. However, eligible micro and small enterprises will be allowed to participate .The buyers are advised to refer the OM No.F.1/4/2021-PPD dated 18.05.2023.

[OM No.1 4 2021 PPD dated 18.05.2023](#) for compliance of Concurrent application of Public Procurement Policy for Micro and Small Enterprises Order, 2012 and Public Procurement (Preference to Make in India) Order, 2017.

4. Purchase preference will be given to MSEs having valid Udyam Registration and whose credentials are validated online through Udyam Registration portal as defined in Public Procurement Policy for Micro and Small Enterprises (MSEs) Order, 2012 dated 23.03.2012 issued by Ministry of Micro, Small and Medium Enterprises and its subsequent Orders/Notifications issued by concerned Ministry. If the bidder wants to avail themselves of the Purchase preference, the bidder must be the manufacturer / OEM of the offered product on GeM. Traders are excluded from the purview of Public Procurement Policy for Micro and Small Enterprises and hence resellers offering products manufactured by some other OEM are not eligible for any purchase preference. In respect of bid for Services, the bidder must be the Service provider of the offered Service. Relevant documentary evidence in this regard shall be uploaded along with the bid in respect of the offered product or service and Buyer will decide eligibility for purchase preference based on documentary evidence submitted, while evaluating the bid. If L-1 is not an MSE and MSE Seller (s) has / have quoted price within L-1+ 15% (Selected by Buyer) of margin of purchase preference /price band defined in relevant policy, such MSE Seller shall be given opportunity to match L-1 price and contract will be awarded for 25% (selected by Buyer) percentage of total quantity. The buyers are advised to refer the OM No. F.1/4/2021-PPD dated 18.05.2023 [OM No.1 4 2021 PPD dated 18.05.2023](#) for compliance of Concurrent application of Public Procurement Policy for Micro and Small Enterprises Order, 2012 and Public Procurement (Preference to Make in India) Order, 2017. Benefits of MSE will be allowed only if seller is validated on-line in GeM profile as well as validated and approved by Buyer after evaluation of documents submitted.

5. Estimated Bid Value indicated above is being declared solely for the purpose of guidance on EMD amount and for determining the Eligibility Criteria related to Turn Over, Past Performance and Project / Past Experience etc. This has no relevance or bearing on the price to be quoted by the bidders and is also not going to have any impact on bid participation. Also this is not going to be used as a criteria in determining reasonableness of quoted prices which would be determined by the buyer based on its own assessment of reasonableness and based on competitive prices received in Bid / RA process.

Conversion Of The Rolled Cupro-Nickel (CN) Strips Into The Accessory, ' Brooch' (100000 pieces)

(Minimum 50% and 20% Local Content required for qualifying as Class 1 and Class 2 Local Supplier respectively/क्रमशः श्रेणी 1 और श्रेणी 2 के स्थानीय आपूर्तिकर्ता के रूप में अर्हता प्राप्त करने के लिए आवश्यक)

Technical Specifications/तकनीकी विशिष्टियाँ

Buyer Specification Document/क्रेता विशिष्टि दस्तावेज़	Download
--	--------------------------

Additional Specification Documents/अतिरिक्त विशिष्टि दस्तावेज़

DrawingDocument1	View
------------------	----------------------

Consignees/Reporting Officer/परेषिती/रिपोर्टिंग अधिकारी and/ तथा Quantity/मात्रा

S.No./क्र. सं.	Consignee Reporting/Officer/ परेषिती/रिपोर्टिंग अधिकारी	Address/पता	Quantity/मात्रा	Delivery Days/डिलीवरी के दिन
1	Indranil Payra	700053,India Govt Mint, Alipore Kolkata , West Bengal	100000	365

Buyer Added Bid Specific Terms and Conditions/क्रेता द्वारा जोड़ी गई बिड की विशेष शर्तें

1. Generic

OPTION CLAUSE: The Purchaser reserves the right to increase or decrease the quantity to be ordered up to 25 percent of bid quantity at the time of placement of contract. The purchaser also reserves the right to increase the ordered quantity by up to 25% of the contracted quantity during the currency of the contract at the contracted rates. Bidders are bound to accept the orders accordingly.

2. Certificates

Bidder's offer is liable to be rejected if they don't upload any of the certificates / documents sought in the Bid document, ATC and Corrigendum if any.

3. Forms of EMD and PBG

Bidders can also submit the EMD with Account Payee Demand Draft in favour of

S P M Corporation of India Limited
payable at
Kolkata

Bidder has to upload scanned copy / proof of the DD along with bid and has to ensure delivery of hardcopy

to the Buyer within 5 days of Bid End date / Bid Opening date.

4. **Forms of EMD and PBG**

Bidders can also submit the EMD with Fixed Deposit Receipt made out or pledged in the name of A/C (Name of the Buyer). The bank should certify on it that the deposit can be withdrawn only on the demand or with the sanction of the pledgee. For release of EMD, the FDR will be released in the favour of the bidder by the Buyer after making endorsement on the back of the FDR duly signed and stamped along with covering letter. Bidder has to upload scanned copy/ proof of the FDR along with bid and has to ensure delivery of hardcopy to the Buyer within 5 days of Bid End date/ Bid Opening date

5. **Forms of EMD and PBG**

Bidders can also submit the EMD with Banker's Cheque in favour of

S P M Corporation of India Limited
payable at
Kolkata

. Bidder has to upload scanned copy / proof of the BC along with bid and has to ensure delivery of hardcopy to the Buyer within 5 days of Bid End date / Bid Opening date.

6. **Forms of EMD and PBG**

Bidders can also submit the EMD with Payment online through RTGS / internet banking in Beneficiary name

S P M Corporation of India Limited
Account No.
40721855110
IFSC Code
SBIN0000205
Bank Name
State Bank of India
Branch address
New Alipore, Kolkata

. Bidder to indicate bid number and name of bidding entity in the transaction details field at the time of on-line transfer. Bidder has to upload scanned copy / proof of the Online Payment Transfer along with bid.

7. **Forms of EMD and PBG**

Successful Bidder can submit the Performance Security in the form of Account Payee Demand Draft also (besides PBG which is allowed as per GeM GTC). DD should be made in favour of

S P M Corporation of India Limited
payable at
Kolkata

. After award of contract, Successful Bidder can upload scanned copy of the DD in place of PBG and has to ensure delivery of hard copy to the original DD to the Buyer within 15 days of award of contract.

8. **Forms of EMD and PBG**

Successful Bidder can submit the Performance Security in the form of Fixed Deposit Receipt also (besides PBG which is allowed as per GeM GTC). FDR should be made out or pledged in the name of

S P M Corporation of India Limited
A/C (Name of the Seller). The bank should certify on it that the deposit can be withdrawn only on the demand or with the sanction of the pledgee. For release of Security Deposit, the FDR will be released in favour of bidder by the Buyer after making endorsement on the back of the FDR duly signed and stamped along with covering letter. Successful Bidder has to upload scanned copy of the FDR document in place of PBG and has to ensure delivery of hard copy of Original FDR to the Buyer within 15 days of award of contract.

9. Forms of EMD and PBG

Successful Bidder can submit the Performance Security in the form of Payment online through RTGS / internet banking also (besides PBG which is allowed as per GeM GTC). On-line payment shall be in Beneficiary name

S P M Corporation of India Limited

Account No.

40721855110

IFSC Code

SBIN0000205

Bank Name

State Bank of India

Branch address

New Alipore, Kolkata

. Successful Bidder to indicate Contract number and name of Seller entity in the transaction details field at the time of on-line transfer. Bidder has to upload scanned copy / proof of the Online Payment Transfer in place of PBG within 15 days of award of contract.

10. Buyer Added Bid Specific ATC

Buyer Added text based ATC clauses

1. Terms and Conditions:

Guidelines of SPMCIL Procurement Manual Version 3.0 will be applicable to this bid at any stage to avoid any conflict at later stage. Kindly refer GIT and GCC of SPMCIL Procurement Manual Version 3.0 for additional terms and conditions as per the links given below:

General Instruction to Tenderer (GIT): <https://igmkolkata.spmcil.com/wp-content/uploads/2024/05/GIT.pdf>

General Conditions of Contract (GCC): <https://igmkolkata.spmcil.com/wp-content/uploads/2024/05/GCC.pdf>

2. Delivery Period:

a) The firm should supply the 1st lot of minimum 10,000 pcs of the finished product i.e. Cupro-Nickel (CN) Brooch within 30 days from the date of issue of Contract. In the event of parallel contract (with 60:40 ratio), quantity will be distributed proportionately.

In the event of failure of the firm to meet the qualitative requirement of the CN Brooch to be supplied at the time of supply of the 1st lot; India Government Mint, Kolkata reserves the right to terminate the contract without citing any further reasons.

After successful supply of the above said 1st lot by the firm, they should supply at the rate of minimum 10,000 pcs of CN Brooch per month. In the event of parallel contract (with 60:40 ratio), quantity will be distributed proportionately.

Overall delivery period will be 12 (Twelve) months from the date of issue of contract and the successful bidders must deliver good quality CN Brooch in full quantity within the stipulated overall delivery date; failing which liquidated damage (LD) charges will be imposed as per standard terms and conditions of tender enquiry.

b) The vendor is responsible for lifting & delivering the material and duly unloading the same at the Bullion Store of India Government Mint, Kolkata after taking necessary security clearance from CISF at the main gate of India Government Mint, Kolkata by showing the driving licence, vehicle registration etc. and necessary documents like invoice, delivery challan, copy of Purchase Order, e-way bill, bank details in company letter head duly sealed & signed etc. are to be handed over to Bullion Store- in- charge.

3. Terms and Mode of payments:

100% on receipt and acceptance of goods & services at destination by the user section of India Government Mint, Kolkata and on production of all required documents by the supplier on every instalment. (Acceptance means goods supplied in proper condition at India Govt. Mint, Kolkata as well as meeting other terms and conditions of Purchase order.)

4. Warranty

a. The supplier warrants that the goods supplied under the contract shall have no defect arising from design, materials (except when the design adopted and / or the material used are as per specifications of India Government Mint, Kolkata) or workmanship or from any act or omission of the supplier, that may develop under normal use of the supplied goods under the conditions prevailing in India.

b. The warranty shall remain valid for **twelve(12) months** after the goods or any portion thereof as the case may be, have been delivered to the final destination and installed and commissioned at the final destination and accepted by India Government Mint, Kolkata in terms of the contract or for fifteen months from the date of despatch from the supplier's premises for domestic goods, whichever is earlier.

c. In case of any claim arising out of this warranty, India Government Mint, Kolkata shall promptly notify the same in writing to the supplier. Upon receipt of such notice, the supplier shall, with all reasonable speed, repair or replace the defective goods or parts thereof, free of cost, at the ultimate destination.

d. The supplier shall take over the replaced parts/ goods after providing their replacements and no claim, whatsoever shall lie on India Government Mint, Kolkata for such replaced parts/ goods thereafter. In the event of any rectification of a defect or replacement of any defective goods during the warranty period, the warranty for the rectified/ replaced goods shall be extended to a further period of twelve months from the date such rectified / replaced goods starts functioning to the satisfaction of India Government Mint, Kolkata.

e. If the supplier, having been notified, fails to rectify/ replace the defect(s) within a reasonable period, India Government Mint, Kolkata may proceed to take such remedial action(s) as deemed fit by India Government Mint, Kolkata (including forfeiture of performance security or warranty security, if any), at the risk and expense of the supplier and without prejudice to other contractual rights and remedies, which India Government Mint, Kolkata may have against the supplier.

5. Replacement:

If the items delivered are rejected for any reasons, the firm has to lift & replace the same at their cost and risk.

6. Custody and return of material loaned to contractor:

Raw Material will be provided by Purchaser i.e, India Government Mint, Kolkata. Whenever raw material is required to be issued to the firm/ contractor, these will be issued against appropriate material custody. The firm must submit material custody equivalent to the value of raw materials issued to them.

Taking present value of Cupro-Nickel (containing Copper and Nickel in 75:25 ratio) as ₹1.61 per g, the total cost of CN material to be issued (equivalent to 100000 pcs of CN Brooch) comes to be = $100000 \times (7.28 + 4.31) \text{ g} \times ₹ 1.61 = ₹ 18,65,990.00$ i.e. (approx.).

The successful firm must submit material custody security for an amount of ₹18,65,990.00/- i.e. (approx.)/- In the event of parallel contract (with 60:40 ratio), amount will be calculated proportionately.

The Successful Firm must submit the material custody security drawn in favour of 'S P M Corporation Of India Limited', payable at Kolkata, from any Scheduled Commercial Bank in acceptable form (i.e: Account Payee Demand Draft/Fixed Deposit Receipt/Bank Guarantee) valid till 60 days beyond the completion of delivery of finished product. If parallel contract is applied, the amount will be in proportionate basis.

7. Packing:

Items should be suitably packed. The packing should be weather proof and should be made water proof to prevent damage during transit. The supplier will also be responsible for unloading and stacking at Mint Bullion Store as per instruction of competent authority.

8. Insurance:

The supplier shall make arrangements for insuring the goods against loss or damage, incidental to manufacture or acquisition, transportation, storage and delivery. The Supplier shall be responsible till the entire goods contracted for arrive in good condition at destination. The transit risk in this respect shall be covered

by the supplier by getting the goods duly insured. The insurance cover shall be obtained by the supplier in its own name not in the name of India Government Mint, Kolkata or its consignee. For details please refer to clause 12 of General Conditions of Contract (GCC).

9. Quantum of LD:

If the supplier fails to deliver any or all of the goods or fails to perform the services within the time frame(s) incorporated in the contract, India Govt. Mint, Kolkata shall, without prejudice to other rights and remedies available to India Govt. Mint, Kolkata under the contract, deduct from the contract price, as liquidated damages, a sum equivalent to the 0.5% of the delivered price of the delayed goods and/ or services for each week of delay or part thereof until actual delivery or performance, subject to a maximum deduction of the 10% of the delayed goods' or services' contract price(s).

10. The total cost inclusive of all as cited above on FOR India Govt. Mint, Kolkata (W.B) basis should be indicated clearly both in words and figures in the price bid.

11. Documentary evidence to be submitted towards PAN & GST Registration Certificate.

12. Participating Bidder must submit sealed and signed copy of entire GeM bid document including the Buyer Specification Document. Also the participating bidder must submit duly filled, sealed & signed **Annexure I, Annexure II & documents as per Annexure III** in their letter head attached under Specification Document.

13. All the supporting documents submitted along with this bid should be signed and sealed by the authorized signatory of the firm mandatorily. The bid document shall not contain any erasure or overwriting, except as necessary to correct any error made by the tenderer and, if there is any such correction; the same shall be initialled by the person(s) signing the tender.

14. The supplier has to provide GeM invoice during submission of bill for payment.

15. Price Schedule:

While quoting the price through GeM portal, the **detailed price breakup must be mentioned and attached as pdf in the document attachment option of price bid mandatorily.** Do not upload financial documents related to financial standings like audited balance sheets in the document attachment field of price bid, attach only the detailed price breakup of the quotation as mentioned above. Detailed price breakup of the quotation must be in the format as attached in the end of this bid document.

Price to be mentioned only in price bid not in Techno commercial bid or any other place. If it is mentioned any other part other than price bid, the offer will be rejected.

16. Qualification/ Eligibility Criteria

A. EXPERIENCE & PAST PERFORMANCE : The bidder should have experience of having successfully completed similar kind of services for the value at least **Rs.38.16 Lakhs** in any one of the last five years ending on 31.03.2023.

Note:

(i) **Similar Kind of Services Means:** Manufacturing products involving operations like cutting, slotting, drilling, soldering, wire drawing, polishing etc. for metals/ metal alloys

(ii) In support of Experience & Past Performance copy of supply/ work order; respective completion certificate and contact details of clients (previous buyer of the items) to be enclosed along with the tender.

(iii) All copy of supply/ work order; respective completion certificate and contact details of clients: in support of experience, past performance should be authenticated by the by the person authorized to sign the tender on behalf of the bidder.

B. CAPABILITY - The bidder must have capability to provide the relevant services.

Note:

(i) In support of the Capability, the bidder has to submit copy of supporting documents i.e: details of equipment and manufacturing facilities, engineers/managers details, number of skilled labors available, Purchase Orders & their Completion Certificates, SOP of Manufacturing Process, quality control systems, annual production capacity etc.

(ii) For verifying the capability/capacity, India Government Mint, Kolkata reserves the right to depute its authorised representatives at the worksites of the bidder. In the event, the firm is found not having capability/capacity, their offer is liable to be rejected.

C. FINANCIAL STANDING :

i) The average annual financial turnover of the bidder during the last three years, ending on 31.03.2023, should be at least **Rs.38.16 Lakhs** as per the annual report (audited balance sheet and profit & loss account) of the relevant period, duly authenticated by a Chartered Accountant/ Cost Accountant in India.

ii)

a) The net worth of the Bidder should not be negative on 31.03.2023 and also

b) Should not have eroded by more than 30% in the last three years, ending on 31.03.2023.

Note:

(i) For net worth erosion calculation of last three(3) years ending on 31.03.2023, audited balance sheet of last three(3) financial years i.e: 2020-21, 2021-22 & 2022-23 must be submitted.

(ii) Supporting documents to be furnished as claim against the above Financial Standing: all financial standing data should be certified by certified accountants, e.g. Chartered Accountants (CA) in India.

(iii) Non-submission or incomplete submission of documents may lead to rejection of offer.

(iv) For MSEs and Start-ups (registered for the tendered item) all financial criteria shall be exempted.

17. Parallel Contracts

(i) Parallel contracts, with more than one bidder (for the same contract) may be concluded in the following cases:

After due processing, if it is discovered that the quantity to be ordered is far more than what L1 alone is capable of supplying and there was no prior decision/ declaration in the bidding documents to split the quantities, then the quantity being finally ordered may be distributed among the other bidders by counter offering the L1 rate in a manner that is fair, transparent and equitable based on objective data available in the bids e.g. eligibility data, Quantity/ Delivery etc.

In case of splitting in two, the ratio of 60:40, respectively, may be used - a different ratio may also be applied for this tender as per requirement of India Government Mint, Kolkata. These ratios are approximate and India Government Mint, Kolkata reserves its right to marginally vary quantities to suit capacity of the firm/ unit loads of packing or transportation. However, the requirements may not be split into a number of tenders of smaller quantities for the reason that one supplier may not be able to supply the entire quantity. It is also to mention in such cases that the firms should not quote for less than 25% of the tendered quantity; otherwise, their offer would be considered as unresponsive.

Before splitting the quantity, it should be ensured that the L1 price is reasonable. If it is not reasonable, negotiation with the L1 party may be carried out, if justifiable, with the approval of the CA. The following guidelines are to be considered while opting for parallel contracts:

i) L1 should be awarded at least the percentage mentioned above or his spare supply capacity, whichever is lower; and

ii) For the rest of the contract quantity, the lowest rate accepted will be counter offered to the L2 party. On acceptance of the counter offer, the order will be placed on L2 for the respective percentage or the spare supply capacity of the L2 bidder, whichever is lower, and so on, to other tenderers. In case of non-acceptance of the counter offer by the L2 party, a similar offer shall be made to L3 and L4, and so on.

18. MSME & Make in India Status:

In case any bidder is submitting their bid as MSME and/or MII, the firm must be registered as a MSME & MII in GeM portal and Self-declaration along with documentary evidence in this regard must be submitted declaring that their MSME & MII status is updated in GeM portal also. In further evaluation stage if it is found that the firm is not registered as MSME and/or MII in GeM, but MSME certificate and/or MII declaration is submitted along with the bid, no exemption will be given and their offer may be rejected.

19. Price Preference for MSE:

MSE quoting price within price band L1 + 15% may be awarded 25% of the total tendered value provided they agree to match the L1 price. In case of more than one such eligible MSE, 25% quantity is to be distributed proportionately among these bidders. Within this, a purchase preference of 4% is reserved for MSEs owned by SC/ ST entrepreneurs' and 3% is reserved for procurement from MSEs owned by women (if they participate in the tender process and match the L1 price, considering spirit of policy for enhancing the Govt. procurement from MSE.

20. Eligible Goods and Services (Origin of Goods & Services):

(i) All goods and services to be supplied and provided for the contract shall have the origin in India or in the countries with which the Government of India has trade relations.

(ii) The word "origin" incorporated in this clause means the place from where the goods are mined, cultivated, grown, manufactured, produced or processed or from where the goods & service are arranged.

21. Special Condition: Supplier should file the returns pertaining to TCS (Section 206C (1H) for TCS collected, in the time and provide the TCS certificate to IGMK. In case of any Credit loss to IGMK by way of their failure to file Returns and provide TCS certificate in time, India Government Mint, Kolkata reserves the right to recover the amount equivalent to TCS paid along with applicable interest from the payment of further supplies.

22. GST Return:

Supplier should file the GST return for outward supplies in time. In case of any loss to India Government Mint, Kolkata by way of their failure to file GST Returns in time India Government Mint, Kolkata reserves the right to withhold the payment of further supplies till production of evidence. Any liability which will occurred on account of non-compliance of e-way bill, GST provision or any other applicable law will be borne by supplier.

23. Consignee:

Chief General Manager, India Government Mint, Alipore, Kolkata, West Bengal, Pin - 700053.

On the consignment please mention the following details:

Order No :	Packing No :	Net Weight :	Gross Weight :
------------	--------------	--------------	----------------

24. Resolution of Disputes:

If dispute or difference of any kind shall arise between India Government Mint, Kolkata and the supplier in connection with or relating the contract, the parties shall make every effort to resolve the same amicably by mutual consultations. If the parties fail to resolve their dispute or difference by such mutual consultation within 21 days of its occurrence, then, depending on the position of the case, either the purchaser or the supplier shall give notice to the other party of its intention to commence arbitration. When the contract is with domestic supplier, the applicable arbitration procedure will be as per Indian Arbitration and Conciliation Act, 1996 as amended by Arbitration and Conciliation (Amendment) Act, 2015 and 2021. Mode of settlement of such contractual disputes/ differences shall be through Arbitration, to the India International Arbitration Centre.

25. Risk Purchase Clause :

(a) If the supplier after submission of tender and due acceptance of the same, i.e. after notification of award of contract fails to abide by the terms and conditions of these tender documents, or fails to supply the deliverables as per delivery schedule given or at any time repudiates the contract, the purchaser shall have the right to:

(i) Invoke the Security-cum-Performance Guarantee if deposited by the supplier and procure stores from other agencies at the risk and consequence of the supplier. The cost difference between the alternative arrangement and supplier tendered value will be recovered from the supplier.

(b) Supplier has to abide by all the terms and conditions of tender.

(c) In case of procurement through alternative sources and if procurement price is lower, no benefit on this account will be passed on to the supplier.

26. Quality Control Requirements:

Quality of Services: Free from all technical defects, in compliance with our Technical Specification

i) Goods/service supplied not in conformity with tender specification will be treated as goods/service not supplied at all and supplier shall take supplied material not conforming to order specification back within 15 days. Goods/service shall be delivered by the supplier in accordance with the terms and conditions specified in the contract failing which expenses of keeping goods at purchaser's premises may be levied on supplier.

ii) Delivery date will be calculated from the date goods/services are received in acceptable quality in accordance with technical specification.

27. Disclaimer:

The issue of this Bid Document does not imply that the Purchaser is bound to select Bidder(s) and the Purchaser reserves the right to reject all or any of the Bidders or Bids or to decide to drop the procurement process at any stage without assigning any reason.

28. The bidder has to submit documents as per following Check list as given below along with the Technical bid documents without fail:

1	Entire Tender Document Duly Seal & Signed on every page including Buyer Specification Document (Annexure-I) as an acceptance of all terms & conditions of the tender
2	Submitted the documents as per Qualification / Eligibility criteria as per Clause 16 of buyer added bid specific ATC (i) Proof of Experience (ii) Proof of Capability (iii) Financial data
3	Documentary evidence towards PAN & GST Registration Certificate
4	Sealed & Signed Declaration (Annexure -II attached in technical specification)
5	Documentary/undertaking against Make in India Status i.e. being a Class I/ Class II supplier with details of percentage
6	Proof of EMD(scanned copy) as applicable or any exemption certificate

-

***FOR ANY OTHER QUERIES, FIRMS MAY CONTACT IN THE BELOW DETAILS:**

Ph. No. 033 - 2401 4132,33,34,35, (Extension 336/ 319/ 326);

Email: purchase.igmk@spmcl.com

.

11. Buyer Added Bid Specific ATC

Buyer uploaded ATC document [Click here to view the file.](#)

Disclaimer/अस्वीकरण

The additional terms and conditions have been incorporated by the Buyer after approval of the Competent Authority in Buyer Organization, whereby Buyer organization is solely responsible for the impact of these clauses on the bidding process, its outcome, and consequences thereof including any eccentricity / restriction arising in

the bidding process due to these ATCs and due to modification of technical specifications and / or terms and conditions governing the bid. If any clause(s) is / are incorporated by the Buyer regarding following, the bid and resultant contracts shall be treated as null and void and such bids may be cancelled by GeM at any stage of bidding process without any notice:-

1. Definition of Class I and Class II suppliers in the bid not in line with the extant Order / Office Memorandum issued by DPIIT in this regard.
2. Seeking EMD submission from bidder(s), including via Additional Terms & Conditions, in contravention to exemption provided to such sellers under GeM GTC.
3. Publishing Custom / BOQ bids for items for which regular GeM categories are available without any Category item bunched with it.
4. Creating BoQ bid for single item.
5. Mentioning specific Brand or Make or Model or Manufacturer or Dealer name.
6. Mandating submission of documents in physical form as a pre-requisite to qualify bidders.
7. Floating / creation of work contracts as Custom Bids in Services.
8. Seeking sample with bid or approval of samples during bid evaluation process. (However, in bids for [attached categories](#), trials are allowed as per approved procurement policy of the buyer nodal Ministries)
9. Mandating foreign / international certifications even in case of existence of Indian Standards without specifying equivalent Indian Certification / standards.
10. Seeking experience from specific organization / department / institute only or from foreign / export experience.
11. Creating bid for items from irrelevant categories.
12. Incorporating any clause against the MSME policy and Preference to Make in India Policy.
13. Reference of conditions published on any external site or reference to external documents/clauses.
14. Asking for any Tender fee / Bid Participation fee / Auction fee in case of Bids / Forward Auction, as the case may be.

Further, if any seller has any objection/grievance against these additional clauses or otherwise on any aspect of this bid, they can raise their representation against the same by using the Representation window provided in the bid details field in Seller dashboard after logging in as a seller within 4 days of bid publication on GeM. Buyer is duty bound to reply to all such representations and would not be allowed to open bids if he fails to reply to such representations.

[This Bid is also governed by the General Terms and Conditions/ यह बिड सामान्य शर्तों के अंतर्गत भी शासित है](#)

In terms of GeM GTC clause 26 regarding Restrictions on procurement from a bidder of a country which shares a land border with India, any bidder from a country which shares a land border with India will be eligible to bid in this tender only if the bidder is registered with the Competent Authority. While participating in bid, Bidder has to undertake compliance of this and any false declaration and non-compliance of this would be a ground for immediate termination of the contract and further legal action in accordance with the laws./जेम की सामान्य शर्तों के खंड 26 के संदर्भ में भारत के साथ भूमि सीमा साझा करने वाले देश के बिडर से खरीद पर प्रतिबंध के संबंध में भारत के साथ भूमि सीमा साझा करने वाले देश का कोई भी बिडर इस निविदा में बिड देने के लिए तभी पात्र होगा जब वह बिड देने वाला सक्षम प्राधिकारी के पास पंजीकृत हो। बिड में भाग लेते समय बिडर को इसका अनुपालन करना होगा और कोई भी गलत घोषणा किए जाने व इसका अनुपालन न करने पर अनुबंध को तत्काल समाप्त करने और कानून के अनुसार आगे की कानूनी कार्रवाई का आधार होगा।

---Thank You/धन्यवाद---

Procurement of service for Conversion of the rolled Cupro-Nickel (CN) strips into the accessory, 'Brooch' as per Drawing Nos. D/184 & D/185 (enclosed herewith), Qty. 1,00,000 pcs

Scope of Work:

Procurement of service for Conversion of the rolled Cupro-Nickel (CN) strips into the accessory, 'Brooch' as per Drawing Nos. D/184 & D/185 (enclosed herewith), Qty. 1,00,000 pcs, with the following scope of work.

A) Scope of supply on India Government Mint, Kolkata's part

1. Rolled Cupro-Nickel (CN) strip of (95 ± 5) mm width and (1.2 ± 0.1) mm thickness with a composition of 75% Copper & 25% Nickel.
2. Rolled Cupro-Nickel (CN) strip of (95 ± 5) mm width and (3 ± 0.2) mm thickness with a composition of 75% Copper & 25% Nickel.

B) Scope of Work on Bidder's/Firm's part

1. Each unit of Brooch consists of 4 parts as below:

i) Slotted & drilled Brooch plate (weight = 3.5 ± 0.05 g)

ii) Pin (weight = 0.55 ± 0.05 g)

iii) Cylindrical hook

iv) C-shaped hook

Total weight of Pin, Cylindrical hook & C-shaped hook will be around (1 ± 0.05) g.

Drawings of the parts cited above are enclosed herewith (Drawing Nos. D/184 & D/185).

a) Rolled Cupro-Nickel (CN) strip of (95 ± 5) mm width and (1.2 ± 0.1) mm thickness will be provided by IGMK for manufacturing the Slotted & drilled Broochplate part.

b) Rolled Cupro-Nickel (CN) strip of (95 ± 5) mm width and (3 ± 0.2) mm thickness will be provided by India Government Mint, Kolkata for manufacturing the other parts e.g. Pin, Cylindrical hook & C-shaped hook.

c) The firm has to supply the materials strictly as per Drawing Nos. D/184 & D/185 and/or the reference sample available at India Government Mint, Kolkata. For reference purpose, representative (/s) of participating vendors may visit India Government Mint, Kolkata.

2. Carrying out all the necessary operations e.g. annealing, cutting, slotting, drilling etc. on rolled CN strip of (95 ± 5) mm width and (1.2 ± 0.1) mm thickness to prepare the trapezoidal broochplate, as per enclosed drawings. Approximate weight of each slotted and drilled broochplate will be (3.5 ± 0.05) g, without Pin, Cylindrical hook and C-shaped hook.

3. Carrying out all the necessary operations e.g. annealing, rolling, cutting, slotting, drilling etc. on rolled CN strip of (95 ± 5) mm width and (3 ± 0.2) mm thickness to prepare the Pin, and both the hooks- one is small cylindrical shaped, while another one is of 'C' shape, as per enclosed drawings. Approximate total weight of each set of Pin and both the hooks will be (1 ± 0.05) g, out of which each Pin will be of (0.55 ± 0.05) g weight without the hooks & broochplate.

4. Silver soldering of Pin as well as both the hooks on the trapezoidal slotted broochplate using standard Silver solder material (68% silver) to make the complete 'Brooch'. Soldering with standard silver is crucial for deposition of thin layer of gold on the soldered points during gold electroplating to be carried out in the finishing stage by India Government Mint, Kolkata.

5. Acid wash, Reetha wash and polishing of complete 'Brooch' to clean brazing/soldering marks and to give it a highly polished finish as per reference sample.

6. Packing and transport to the India Government Mint, Kolkata.

NB:

1. The firm may visit India Government Mint, Kolkata (with prior intimation) to see the material.

2. Sample of brooch will be provided to the successful bidder firm by India Government Mint, Kolkata on returnable basis.

3. For each unit of Brooch, raw material as per following details will be provided:

a) For slotted and drilled Broochplate part,

Rolled Cupro-Nickel (CN) strip of (95 ± 5) mm width and (1.2 ± 0.1) mm thickness = 7.2775 g i.e. 7.28 g (approx.).

(Considering 50% yield in manufacturing each Slotted & drilled Broochplate part with a process loss of maximum 2.5%)

b) For set of Pin and Cylindrical hook & C-shaped hook,

Rolled Cupro-Nickel (CN) strip of (95 ± 5) mm width and (3 ± 0.2) mm thickness = 4.305 g i.e. 4.31 g (approx.).

(Considering 25% yield in manufacturing each set of Pin, Cylindrical hook & C-shaped hook with a process loss of maximum 2.5%)

c) Apart from the process loss part, the firm shall have to return all the excess CN materials (if any) alongwith the specified quantities of complete Brooch (1,00,000 nos.).

DRAWING OF COMPLETE BROOCH

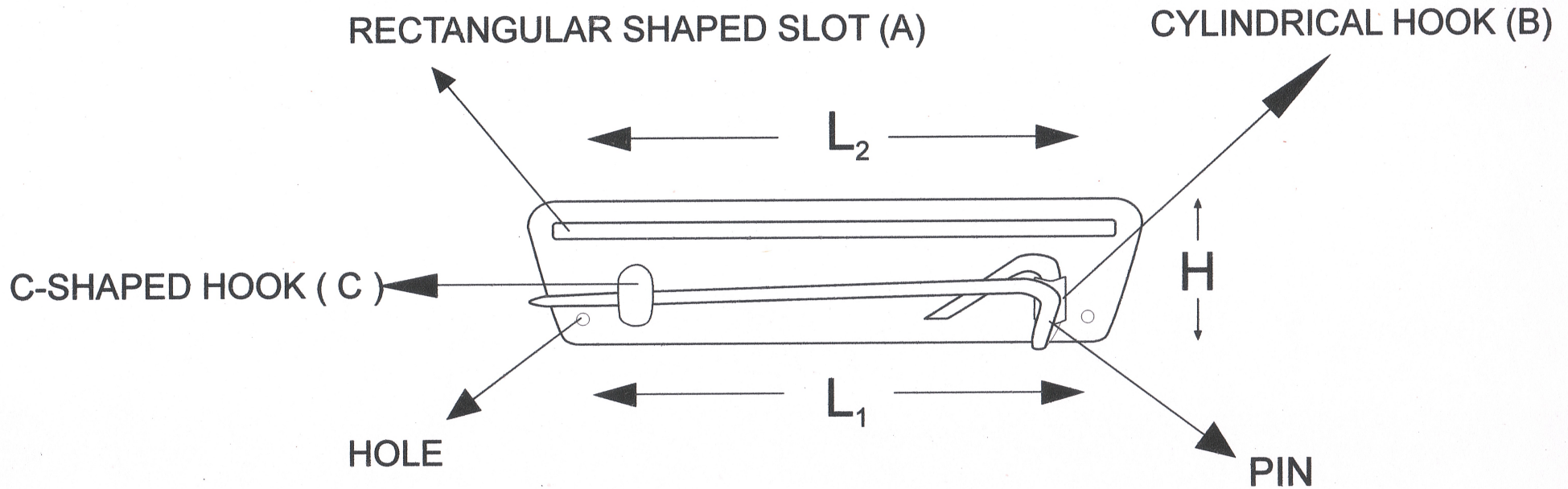

$L_1 = 32.4 \text{ mm } (\pm 0.05 \text{ mm})$

$L_2 = 37.5 \text{ mm } (\pm 0.05 \text{ mm})$

$H = 10.15 \text{ mm } (\pm 0.05 \text{ mm})$

$A = 35 \text{ mm } (\pm 0.05 \text{ mm}) \times 1.15 \text{ mm } (\pm 0.05 \text{ mm})$

$C = 7.0 \text{ mm } (\pm 0.05 \text{ mm}) \times 4.0 \text{ mm } (\pm 0.05 \text{ mm})$

Thickness of C = 1.3 mm

$B = 3.75 \text{ mm } (\pm 0.05 \text{ mm}) \times 2.95 \text{ mm } (\pm 0.05 \text{ mm})$

Thickness of Brooch Plate = 1.2 mm ($\pm 0.02 \text{ mm}$)

Thickness of Pin = 1.3 mm ($\pm 0.02 \text{ mm}$)

Weight of Brooch = 4.5 g ($\pm 0.1 \text{ g}$)

Dia of hole = 1.4 mm ($\pm 0.1 \text{ mm}$)

Material - Cupronickel (Copper = 75%, Nickel = 25%)

INDIA GOVERNMENT MINT,
KOLKATA

DATE:
09/05/2022

DRAWING NO. :
D/184

DRAWING OF COMPONENTS

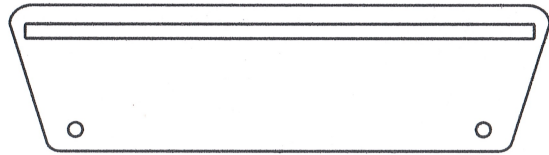

TRAPEZOID SHAPED SLOTTED & DRILLED BROOCH PLATE
(WEIGHT $3.5g \pm 0.05g$)

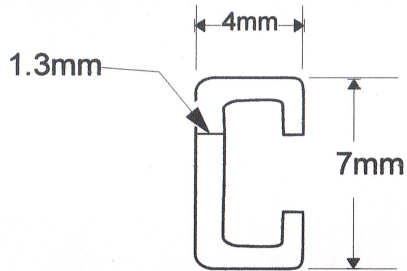
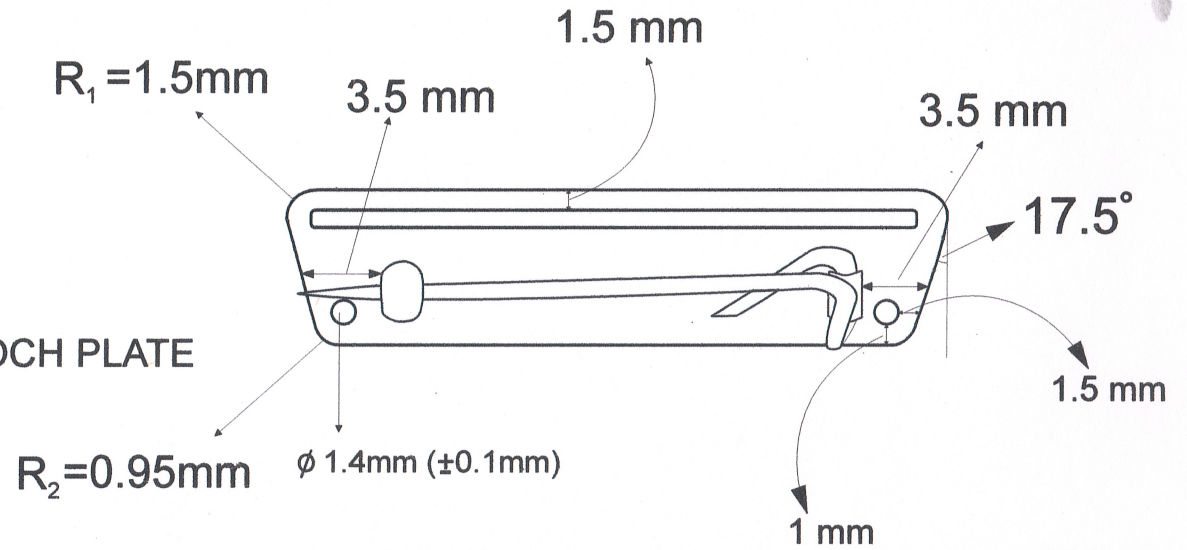

C - SHAPED HOOK

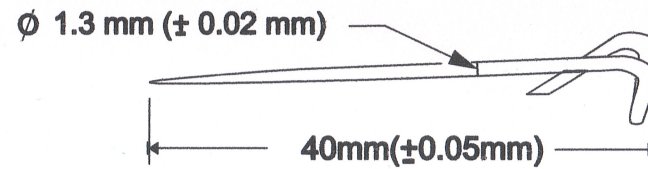

PIN

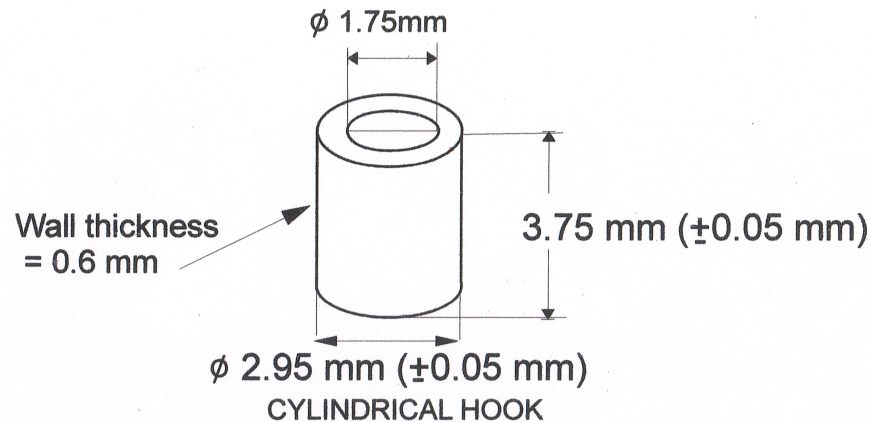

INDIA GOVERNMENT MINT,
KOLKATA

DATE:
09/05/2022

DRAWING NO. :
D/185

ANNEXURE - II

**GeM Bid Document No. :dated.
(To be submitted on the letter head of the bidder)**

DECLARATION

We do hereby declare that,

- 1. We have not been blacklisted/ debarred by BNPMIPL/BRBNMPL/SPMCIL or any Govt. Departments for participation in tenders. The information provided above is correct and true to the best of my knowledge and belief.
- 2. We do hereby declare that we have read and understood all terms and conditions of tender document including Technical Specification, Quality Control Criteria, Buyer added bid specific ATC and confirm to abide to those conditions without any counter conditions.
- 3. "We are accepting all the terms and conditions of the GeM tender document unconditionally without any deviations"
- 4. We do accept all the terms and conditions of GIT & GCC link given in buyer added bid specific ATC without any deviation.

Signature

Name

Designation

Date

Stamp of the Organization

IMPORTANT

Before submission of Tender, please fill up & submit the following points in your company letter head duly sealed & signed.

We have submitted following documents:

1. Entire GeM Bid document duly sealed & signed every page (including Annexure I , Annexure II & Annexure III duly filled sealed and signed)
2. Proof of EMD(scanned copy) as applicable or any exemption certificate
3. Documentary evidence towards PAN & GST Registration Certificate duly sealed and signed.
4. Documentary/undertaking against Make in India Status i.e: being a Class I/Class II Supplier with details of Percentage
5. The firms participating as MSE/NSIC/DIC/Start-up India Campaign, needs to enclose certificates containing validity.
6. If participating as MSME, then please mention Category of MSME Firm: SC/ST/GEN. Owner of the company Male/Female.
7. Copies of Purchase Orders & their Completion Certificates for Past Experience.
8. Relevant Documents (i.e: details of equipment and manufacturing facilities, engineers/managers details, number of skilled labors available, Purchase Orders & their Completion Certificates, SOP of Manufacturing Process etc.) for Capability
9. Audited Balance sheet for F.Y 2020-21, 2021-22 & 2022-23 for Financial Standing.
10. We have quoted price only in Price Bid and not in Techno-commercial Bid.

Note:

The above document must be enclosed otherwise tender will be rejected.

PRICE SCHEDULE

Procurement of service for Conversion of the rolled Cupro-Nickel (CN) strips into the accessory, 'Brooch' as per Drawing Nos. D/184 & D/185 (enclosed herewith), Qty. 1,00,000 pcs (Price to be quoted as per Annexure-I Buyer Specification Document, inclusive of all, complete in all respect)

Quantity: 1,00,000 Pieces

Basic Price/ 1 Piece :

Other Charges (If any) :

GST/ 1 Piece :

Total Price including all for 1 Piece:

Total Price including all for 1 Piece in words:

Total Price including all for 1,00,000 Pieces on FOR, IGM, Kolkata basis at India Government Mint, Kolkata:

Total Price including all for 1,00,000 Pieces on FOR, IGM, Kolkata basis at India Government Mint, Kolkata in **words**:

Abbreviation "FOR" Free on Rail(i.e: Landed cost to the India Govt. Mint, Kolkata inclusive of all taxes & duties), "IGM" India Government Mint.

NOTE :

1. L1 firm will be declared from valid offers only those who submitted offer as per specification & as per all terms & condition of the tender. If there is any deviation in specification & if the offer is not found as per terms & condition of the tender, their offer will be treated as invalid/unresponsive offer.
2. Price to be mentioned only in price bid not in Techno commercial bid or any other place. If it is mentioned any other part other than price bid, the offer will be rejected.