

फोन/Ph: +91-33-24014132-36
फैक्स/Fax: +91-33-24010553

वेबसाइट/Website: http://igmkolkata.spmcil.com
ई-मेल/E-mail: calmint@spmCIL.com

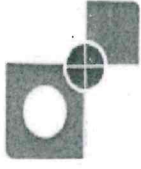

भारत सरकार टकसाल
INDIAGOVERNMENTMINT

(भारत प्रतिभूति मुद्रण तथा मुद्रा निर्माण निगम लिमिटेड की एक इकाई)
(A Unit of Security Printing and Minting Corporation of India Limited)
(मिनिरत्न, श्रेणी-I सीपीएसई / A Mini Ratna, Category-I CPSE)



आईएसओ 9001:2008 एवं 14001:2004 प्रमाणित कंपनी / An ISO 9001:2008 & ISO 14001:2004 Certified Company
भारत सरकार के पूर्ण स्वामित्वाधीन / Wholly Owned by Government of India
अलीपुर / Alipore, कोलकाता / Kolkata - 700 053
Corporate Identity Number (CIN): U22213DL2006GOI144763

No. 54/T-133(24-25)/GEM/2024/B/5607264/Addendum-I

Date: 18.12.2024

To,

The Bidders

Reference Tender Document No. 54/T-133(24-25)/GEM/2024/B/5607264 Dated: 22.11.2024

Subject: Procurement of Graphite Crucible for 45 KW Vacuum Gold Bar Machine in Melting department

Addendum-I

Sir/Madam,

- With reference to above, the Drawing as per 'Annexure-A' (attached below) is added to this bid document.
- Accordingly last date of submission of the tender through GeM portal is extended as below:

Bid Document Lines	Earlier		Read As	
Bid End Date/Time	23.12.2024	15:00:00	01.01.2025	15:00:00
Bid Opening Date/Time	23.12.2024	15:30:00	01.01.2025	15:30:00

All other terms & conditions of the subjected tender will remain unchanged.

This is issued with the approval of Competent Authority.

Yours faithfully,

Jt. GM (TO) & MATERIALS HEAD
For General Manager & HoD

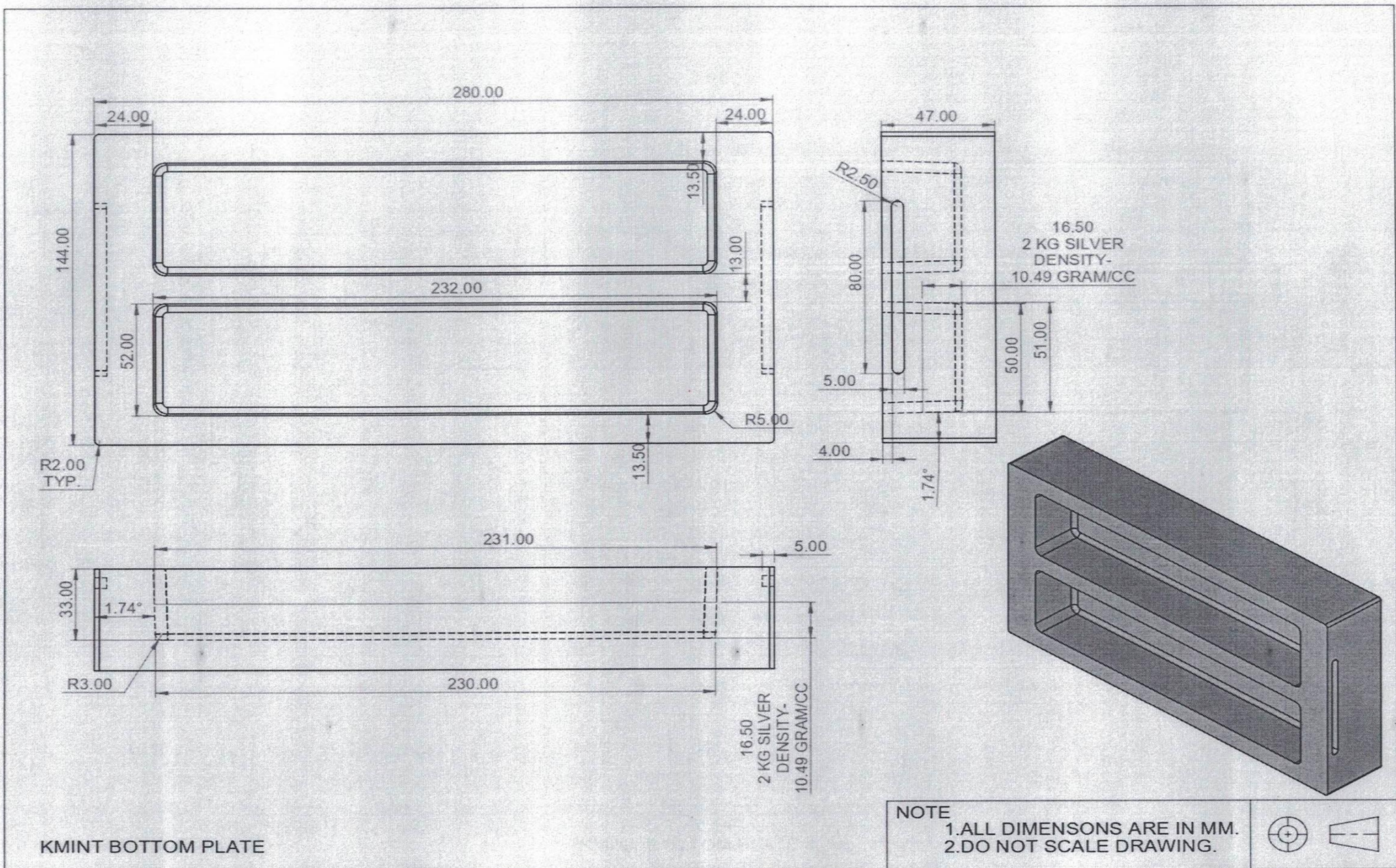

KMINT BOTTOM PLATE

NOTE
 1. ALL DIMENSIONS ARE IN MM.
 2. DO NOT SCALE DRAWING.

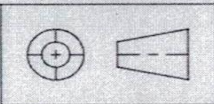

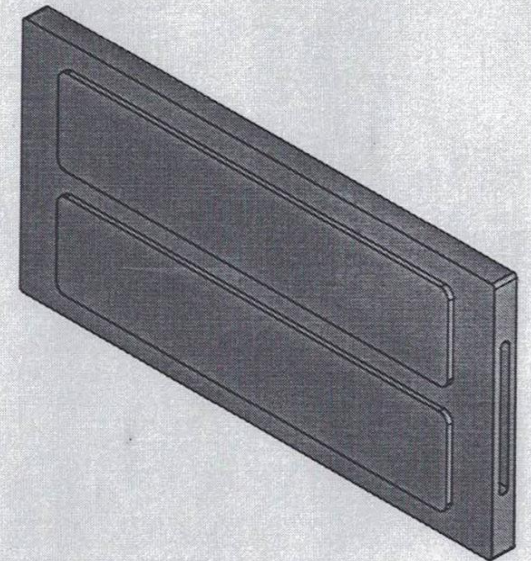
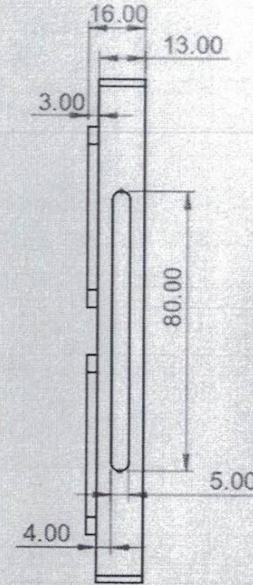
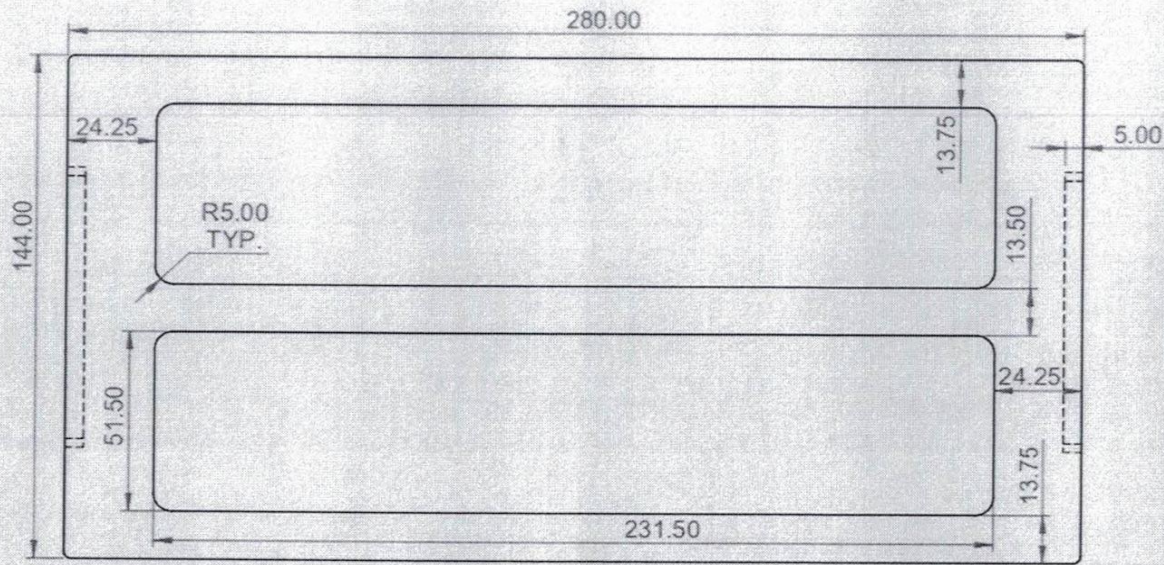

KMINT TOP PLATE

NOTE

1. ALL DIMENSIONS ARE IN MM.
2. DO NOT SCALE DRAWING.

